

EVEREST GEN7 FENDER TEMPLATE

INSTRUCTIONS

- 1. Print template at 100% size and orientation as landscape.
- 2. Cut template along dotted line
- 3. Align template with body shell trim edge
- 4. Temporarily secure template to body with tape
- 5. Locate the center of all nine targets. Use a body reamer or hole punch to create screw holes

TOOLS NEEDED

Scissors

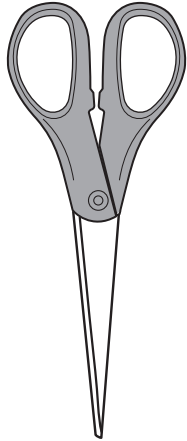

Body Reamer

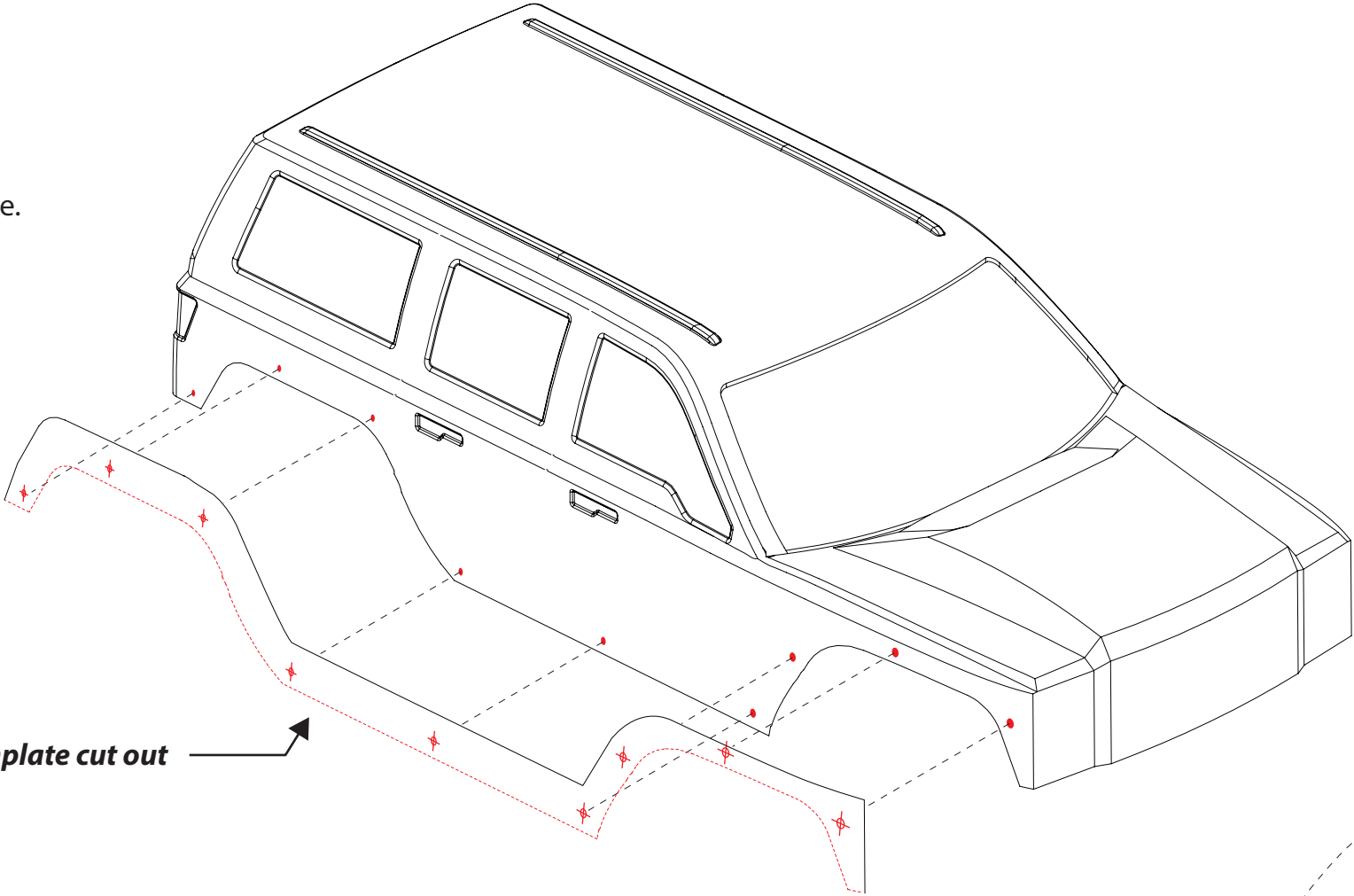
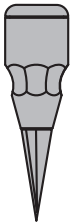

Cut along dotted line →

FRONT →

FENDER TEMPLATE

0.25cm Diameter Hole

Body trim edge

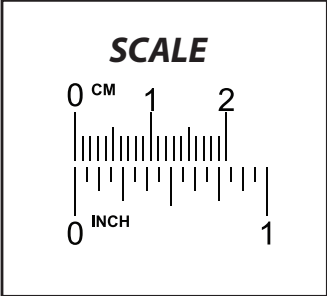

TIP: Make a small dimple in the body shell before drilling holes. Use dimples to confirm all holes are correctly aligned to the plastic fender screw holes. Once proper alignment is confirmed, drill final 0.25cm diameter holes.