

# CREALITY

## Multi-Function Module Machine User Manual

多功能模组机使用说明书

CP-01

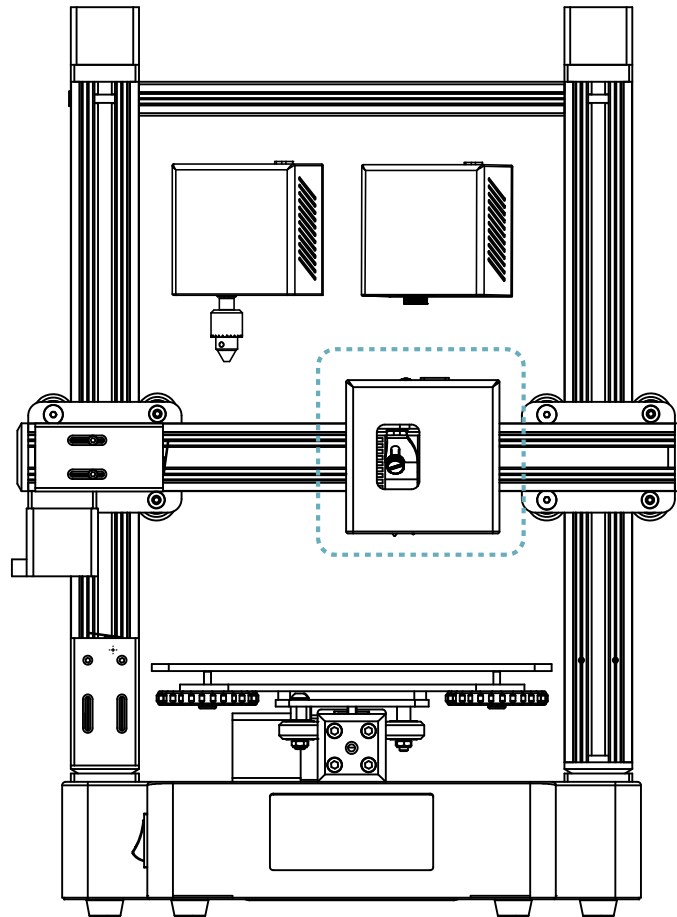

V2.3

# Content 目录

Dear Consumers,

Thank you for choosing our products. For the best experience, please read the instructions before operating the Printer. Our teams will always be ready to render you the best services. Please contact us via the phone number or e-mail address provided at the end when you encounter any problem with the Printer.

For a better experience in using our product, you can also learn how to use the Printer in the following ways:

View the accompanied instructions and videos in the Storage card.

Visit our official website [www.creality.com](http://www.creality.com) to find relevant software/hardware information, contact details and operation and maintenance instructions.

尊敬的创想三维用户：

感谢您选择、使用创想三维的产品。为了您使用方便，请您在使用之前仔细阅读该说明书，并严格按照说明书的指示进行操作。

创想三维团队时刻准备为您提供优质的服务。在使用过程中无论遇到什么问题，请按照说明书结尾所提供的电话、邮箱与我们联系。

为了您能够更好地体验我们的产品，您还可以从以下方式获取设备操作知识：

随机使用说明：您可以在存储卡内找到相关使用说明及视频。

创想三维官网：[www.cxsw3d.com](http://www.cxsw3d.com) 您可以登陆创想三维官网寻找相关软硬件、联系方式、设备操作、设备保养等信息。

## A

### Notes

使用须知

## B

### Assemble the 3D Printer

组装 3D 打印机

## C

### Use the 3D Printer

使用3D打印机

### Level the Heated Bed

调平

### Load Filament

装料

### Start Printing

开始打印

## D

### Use the Laser Engraving

使用激光雕刻机

## E

### Use the CNC Engraving

使用CNC雕刻机

## NOTES 使用须知

1. Do not use the printer any way other than described herein in order to avoid personal injury or property damage.
2. Do not place the printer near any heat source or flammable or explosive objects. We suggest placing it in a well-ventilated, low-dust environment.
3. Do not expose the printer to violent vibration or any unstable environment, as this may cause poor print quality.
4. Before using experimental or exotic filaments, we suggest using standard filaments such as ABS or PLA to calibrate and test the machine.
5. Do not use any other power cable except the one supplied. Always use a grounded three-prong power outlet.
6. Do not touch the nozzle or printing surface during operation as they may be hot. Keep hands away from machine while in use to avoid burns or personal injury.
7. Do not wear gloves or loose clothing when operating the printer. Such cloths may become tangled in the printers moving parts leading to burns, possible bodily injury, or printer damage.
8. When cleaning debris from the printer hotend, always use the provided tools. Do not touch the nozzle directly when heated. This can cause personal injury.
9. Clean the printer frequently. Always turn the power off when cleaning, and wipe with a dry cloth to remove dust, adhered printing plastics or any other material off the frame, guide rails, or wheels. Use glass cleaner or isopropyl alcohol to clean the print surface before every print for consistent results.
10. Children under 10 years of age should not use the printer without supervision.
11. This machine is equipped with a security protection mechanism. Do not manually move the nozzle and printing platform mechanism manually while booting up, otherwise the device will automatically power off for safety.
12. Users shall comply with related nation and region's laws, regulations and ethical codes where the equipment or produced prints by it is used, and users of our product shall not use aforesaid products to print any end-use products, objects, parts or components or any other physical prints that violate the national or regional laws, regulations and ethical codes where herein referred product and produced prints by it is located.

- 1、请勿尝试任何使用说明中没有描述的方法来使用本机，避免造成的意外人身伤害和财产损失；
- 2、请勿将本机放置在易燃易爆物品或高热源附近，请将本机放置在通风、阴凉、少尘的环境内；
- 3、请勿将打印机放置在振动较大或者其他不稳定的环境内，机器晃动会影响打印机打印质量；
- 4、建议使用厂家推荐耗材，以免造成挤出头堵塞和机器损坏；
- 5、请勿在安装过程中使用其他产品电源线代替，请使用本机附带的电源线，电源插头需接插在带有地线的三孔插座；
- 6、请勿在打印机工作时接触喷嘴以及热床，以防止出现高温烫伤，造成人身伤害；
- 7、请勿在操作机器时佩戴手套或缠绕物，以防可动部件对人身部件造成卷入挤压和切割伤害；
- 8、在打印完毕后及时利用喷头的余温借助工具将喷头上的耗材清理干净，清理时请勿直接用手触摸喷头，以防出现烫伤；
- 9、常做产品维护，定期在断电的情况下，用干布对打印机做机身清洁，拭去灰尘和粘结的打印材料、导轨上的异物；
- 10、年龄在10岁以下的儿童，请勿在没有人员监督的情况下使用本机，以免造成人身伤害；
- 11、本机设有安全保护机制，请勿在开机状态下手动快速移动喷头及打印平台机构，否则设备会自动断电关机保护；
- 12、使用者应遵守设备打印产品与设备所在地及相应国家及地区法律、法规，恪守职业道德，严禁使用我司产品打印有违设备打印产品与设备所在地及相应国家、地区法律禁止的任何产品或物件。

# Introduction 设备简介

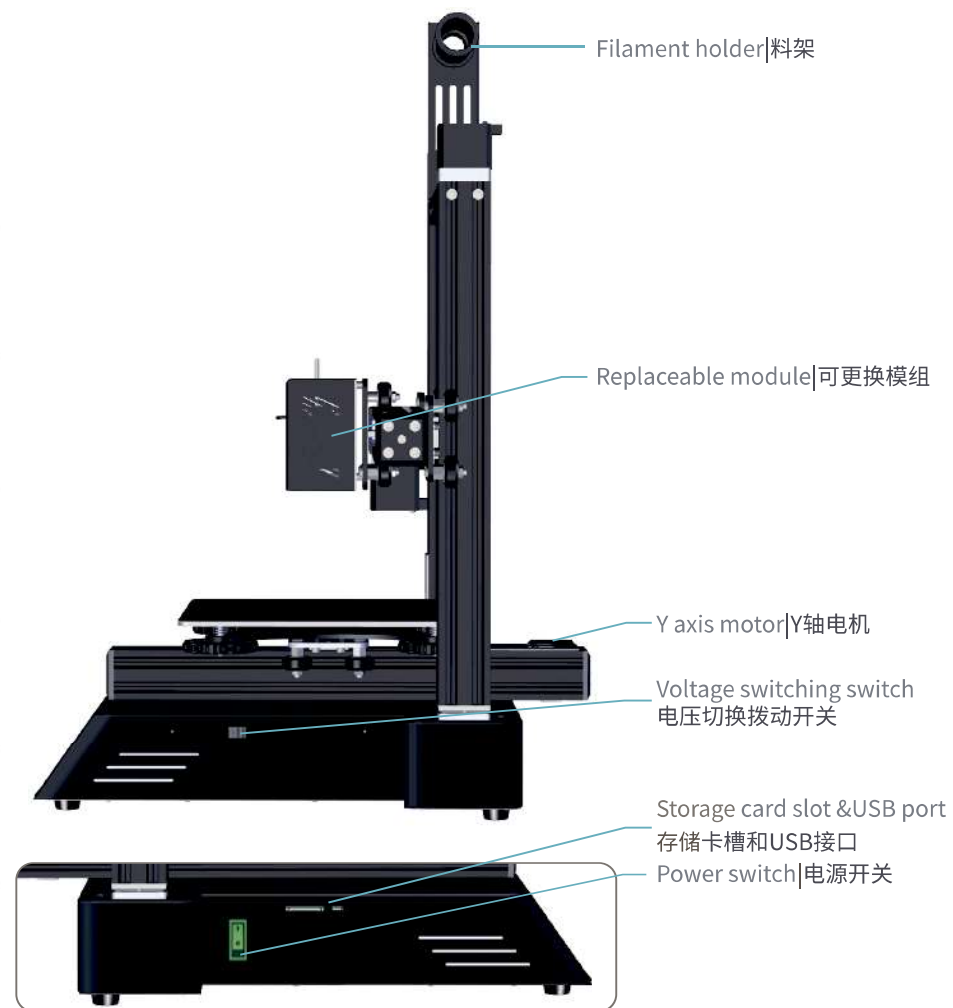
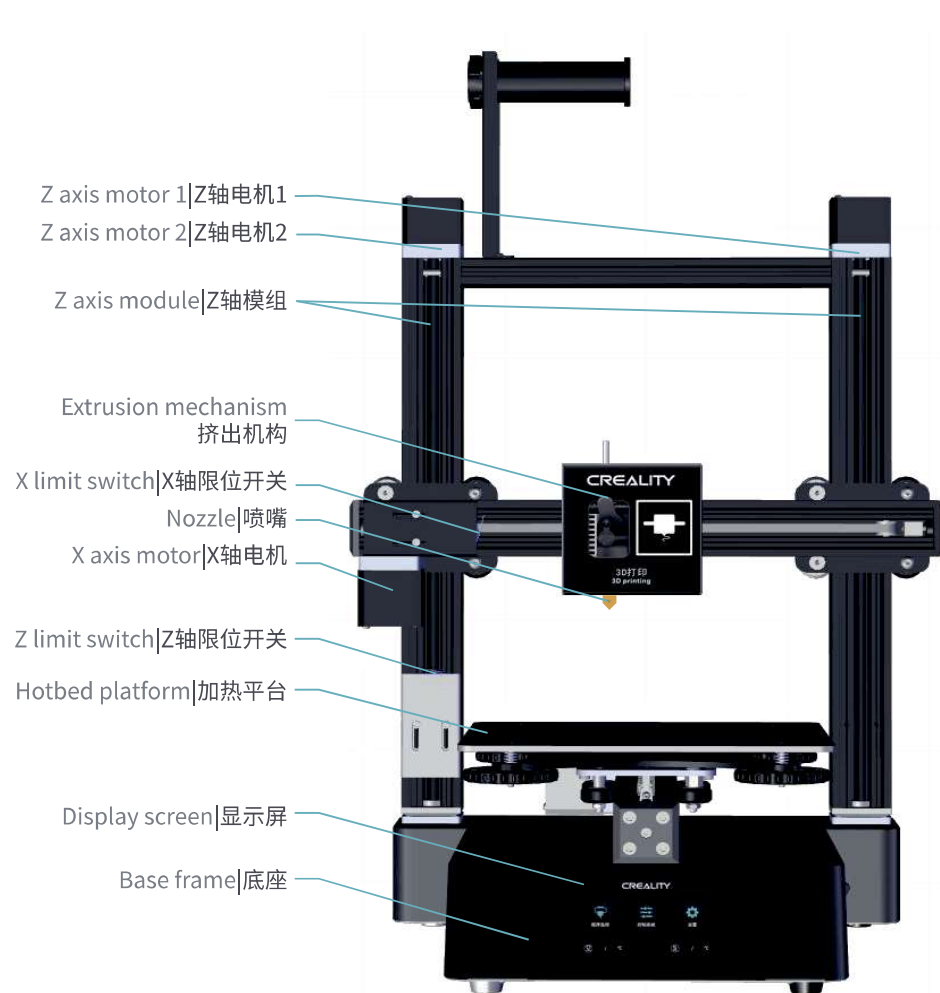

# Parameters 设备参数

3D Printing Basic Parameters 3D打印基本参数	
Model   型号	CP-01
Printing Size   成型尺寸	200*200*200mm
Molding Tech   成型技术	FDM
Nozzle Number   喷头数量	1
Slice Thickness   切片层厚	0.1mm-0.4mm
Nozzle Diameter   喷嘴直径	Standard 0.4mm   标配0.4mm
Precision   打印精度	±0.1mm
Filament   打印材料	1.75mm PLA
File Format   切片支持格式	STL/OBJ/AMF
Working Mode   打印方式	Online or Storage card offline   联机或存储卡脱机
Slice Software   可兼容切片软件	Creativity Slicer/Cura/Repetier-Host/Simplify3D
Power Supply   额定电压	Input  输入:AC115/230V 50/60Hz
Output Voltage   输出电压	24V
Total Power   额定功率	350W
Bed Temp   热床最高温度	≤100°C
Nozzle Temp   喷嘴最高温度	≤250°C
Resume Print   断电续打	Yes   有
Filament Detector   断料检测	No   无
Daul Z-Axis   双Z轴	Yes   有
language Selection   中英切换	Yes   有
Operating System   电脑操作系统	Windows XP/7/8/10 MAC/Linux
Printing Speed   打印速度	≤180mm/s,Normal 正常为 30-60mm/s

Laser Engraving Basic Parameters 激光雕刻基本参数	
Engraving size   雕刻尺寸	200*200mm
Supported filament 支持材料	Wood, paper, plastic, leather, etc. 木、纸、塑料、皮革、竹子
File format 支持文件格式	JPG
Slice Software   可兼容切片软件	CreativityWorkshop-en

CNC Engraving Basic Parameters CNC雕刻基本参数	
Engraving size   雕刻尺寸	200*200mm
Main spindle rotational speed 主轴转速	4800rpm Max
Supported filament 支持材料	wood, paper, PCB, plastic, etc. 木、纸、PCB、塑料
Standard cutter size 标配刀具尺寸	HRC55 tungsten steel milling cutter 4F 4*1 HRC55钨钢铣刀4F 4*1
File format 支持文件格式	JPG
Drill chuck clamping range 钻夹头夹持范围	0.3-0.4mm
Slice Software   可兼容切片软件	CreativityWorkshop-zh

## Parts List 零部件清单

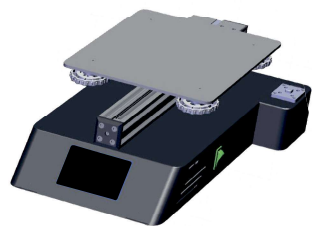

1 Base Frame x1  
底座



2 Gantry Frame x1  
龙门架

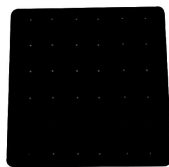

3 Carving Platform x1  
雕刻平台



4 3D Print Head x1  
3D打印头



5 Laser Machine Head x1  
激光雕刻头



6 CNC Machine Head x1  
CNC雕刻头

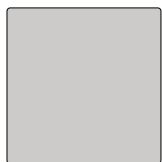

7 Acrylic sheet x1  
亚克力板



8 Board x1  
木板

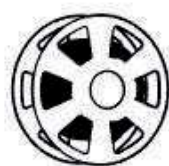

9 Filament(200g) x1  
耗材(200g)

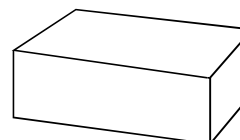

10 Tool Box x1  
工具包



11 Power Cord x1  
电源线

## Tool list 工具包清单



12 Wrench & Screw Driver x1  
扳手和螺丝刀



13 Storage Card & x1  
Card Reader  
存储卡和读卡器



14 Spatula x1  
铲刀

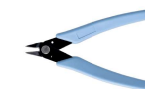

15 Pliers x1  
斜口钳



16 Nozzle Cleaner x1  
通针



17 M4\*8 Hand Twist Nut x10  
M4\*8手拧螺丝



18 M4\*8 Hexagon Socket  
Cap Screws  
M4×8内六角圆柱头螺丝



19 M4\*8 Hexagon Socket  
Button Head Screws  
M4×8内六角平圆头螺丝



20 M4 T-Nut x6  
M4T型螺母



21 Filament Holder x1  
料架



22 Filament Holder x1  
Tube with Nuts  
料管及螺母



23 M4\*50 Hexagon x4  
Countersunk Head Screw  
M4\*50内六角沉头螺丝



24 A&B Code x4  
A、B码仔



25 CNC Safety Goggles x1  
CNC防护眼镜



26 Teflon Tube x1  
铁氟龙管



27 Spare Parts x1  
备品



28 M5\*40 Sems Screw x12  
M5\*40组合螺丝



29 Versatile Wrench x1  
多功能小扳手



30 M3X10 Set Screw x6  
M3X10圆柱头螺丝



31 Laser Safety Goggles x1  
激光防护眼镜



32 R Type Clamp x2  
R型线夹



33 Engraving Tools x1  
铣刀



34 M4 butterfly nut x4  
M4蝶型螺母



35 Cable Ties x1  
扎带

# 1

## Install the Gantry Frame 安装龙门架

Put the gantry on the base, tighten and fix it with 8 M5\*40 combination screws  
用8颗M5\*40组合螺丝将龙门架放置于底座上, 拧紧固定

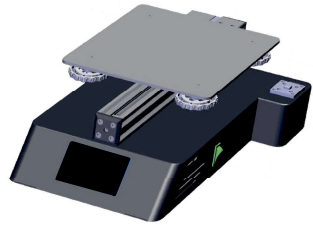

1 Base Frame x1  
底座



2 Gantry Frame x1  
龙门架



28 M5\*40 Sems Screw x8  
M5\*40组合螺丝

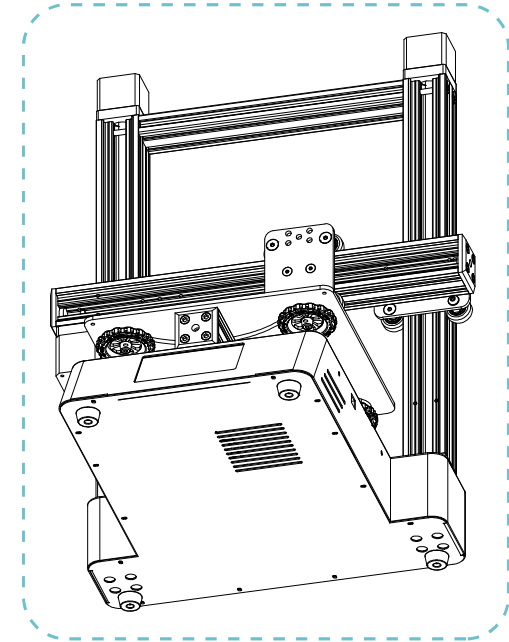
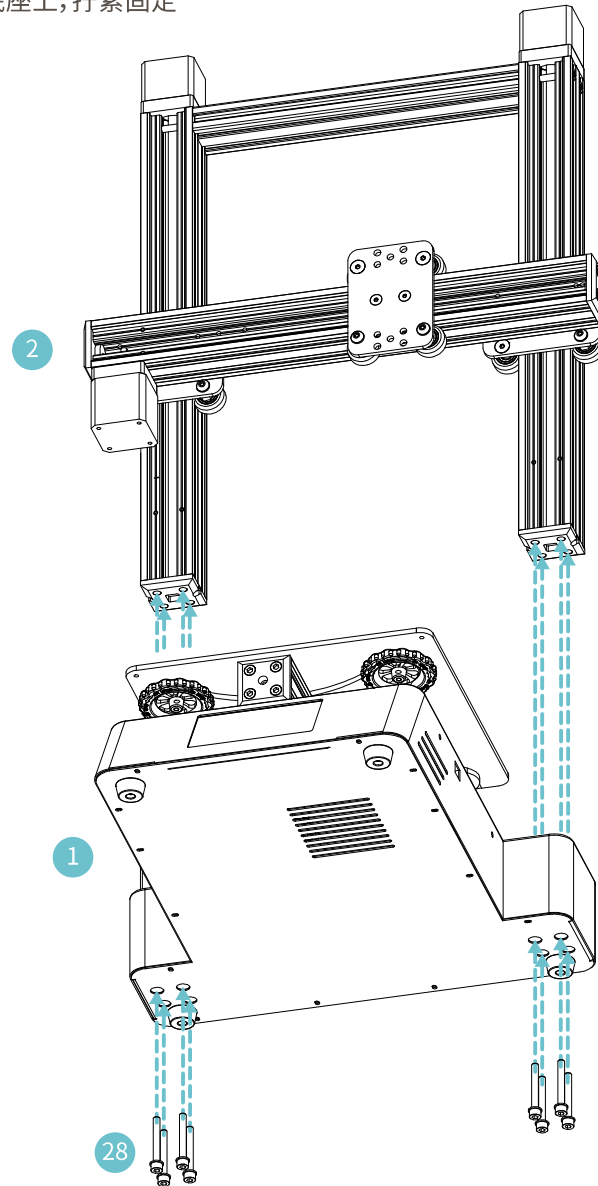

# 2

## Install the 3D Print Head 安装3D打印头

Install the machine head and fix it with 3 thumb screws or 3 M4\*8 hexagon socket cap screws  
安装机头,用3颗手拧螺丝或3颗M4×8内六角圆柱头螺丝拧紧固定



- 4 3D Print Head x1  
3D打印头



- 17 M4\*8 Hand Twist Nut x3  
M4\*8手拧螺丝



- 18 M4\*8 Hexagon Socket Cap Screws x3  
M4×8内六角圆柱头螺丝

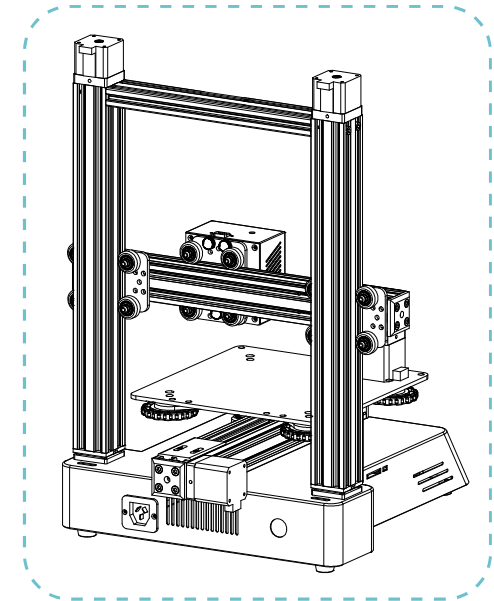
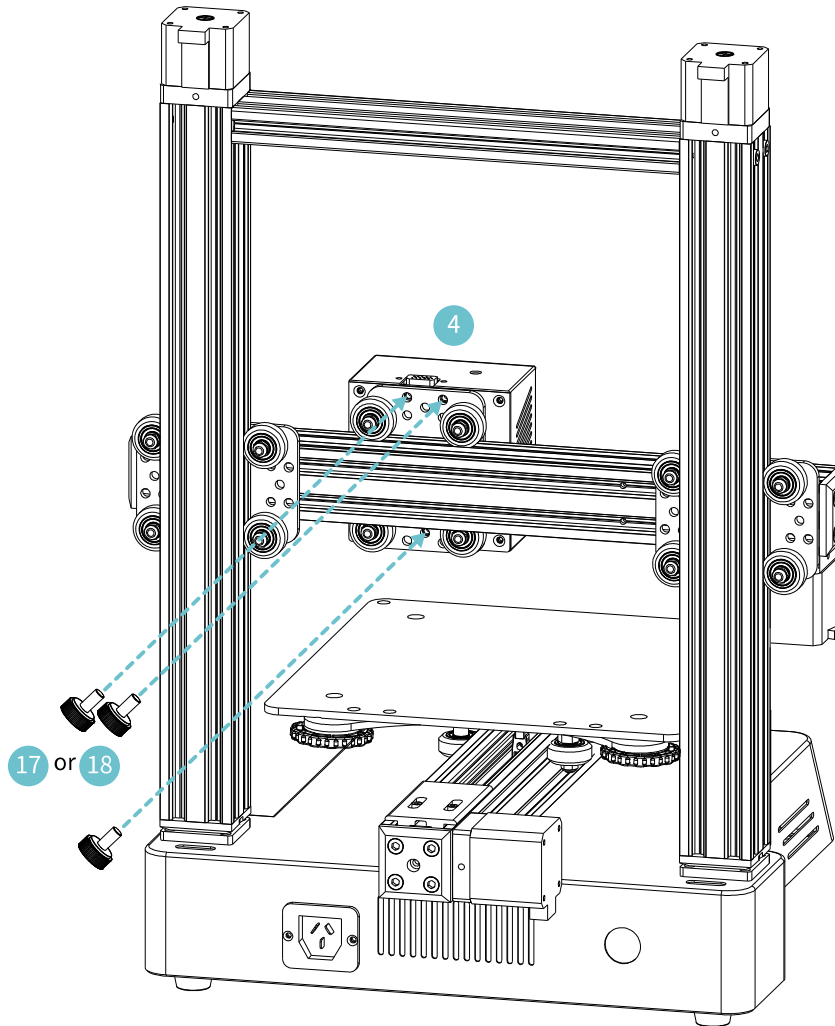



# 3

## Install the Z axis and X axis Limit Switch 安装Z轴和X轴限位开关

Fix the limit switch for Z axis and X axis with 2 M3\*10 cylindrical head screws  
用4颗M3X10圆柱头螺丝将Z轴、X轴限位开关固定



30 M3X10 Set Screw x4  
M3X10圆柱头螺丝

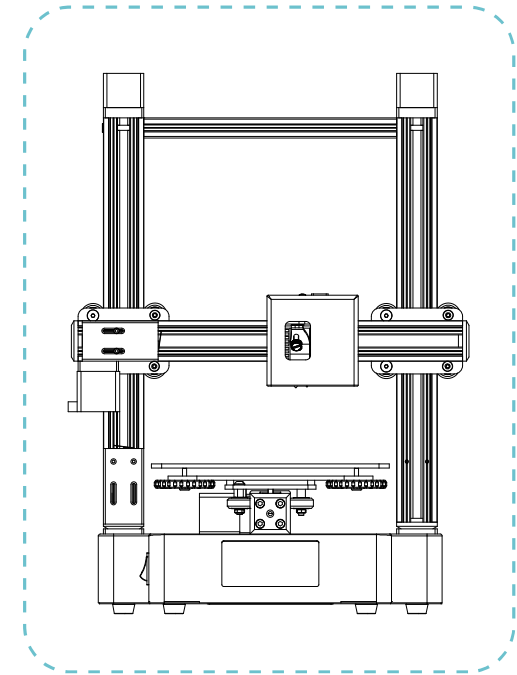
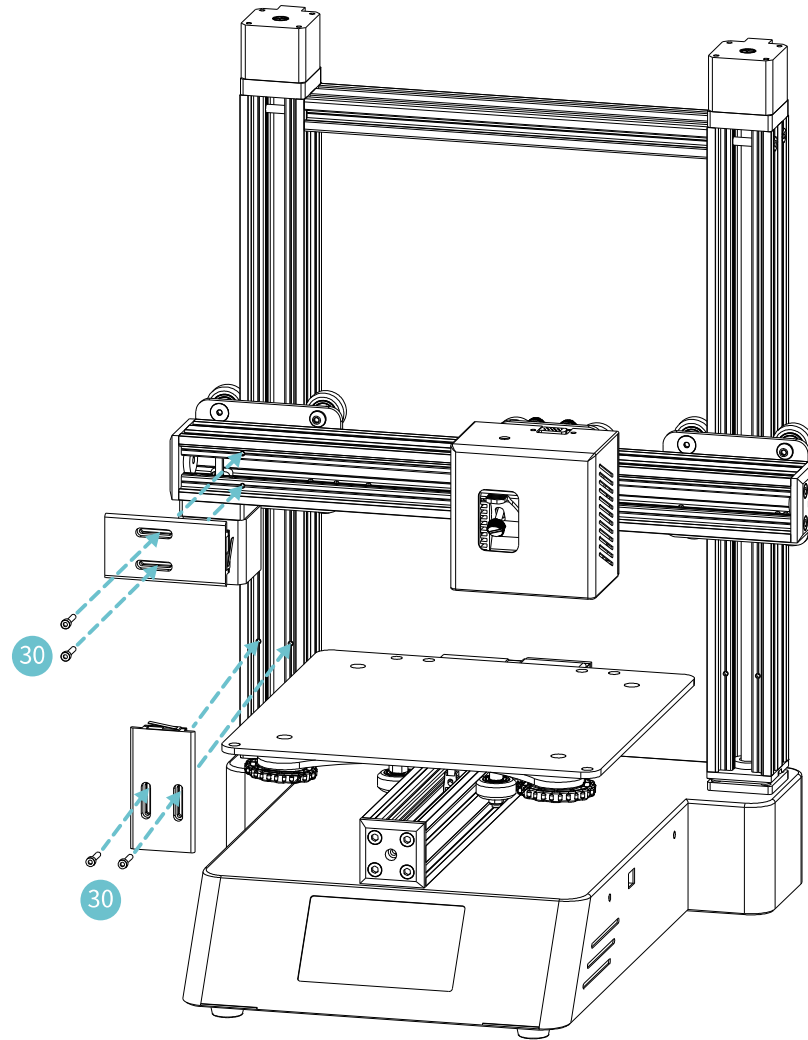

# 4

## Cable Connection 设备接线

1. Insert signal wire into machine head
  2. Connect the X axis motor line
  3. Fix the line of X axis limit switch and X axis motor with R type clip
1. 将信号线插入机头 2. 连接X轴电机线 3. 用R型夹固定X轴限位开关和X轴电机的线



32 R Type Clamp x1  
R型线夹

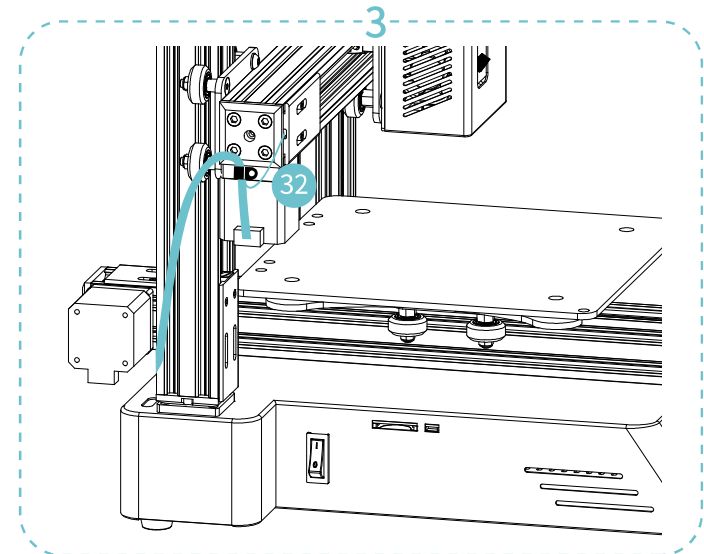
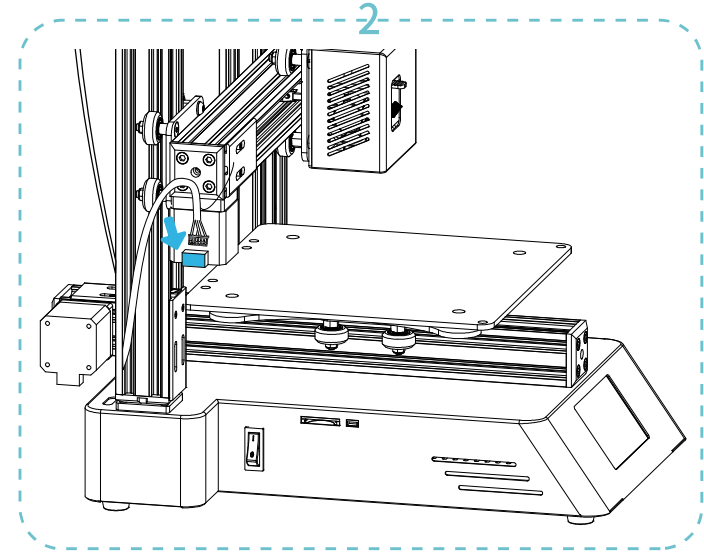
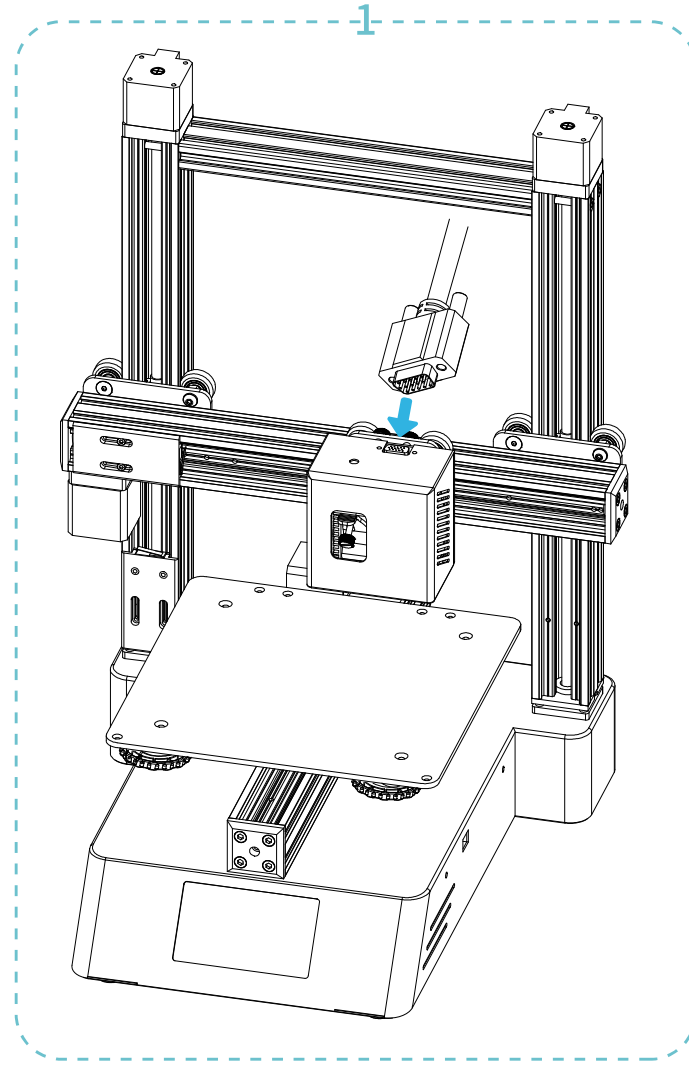

# 5

## Cable Connection 设备接线

4. Connect the Two Z axis motors line 5. Install decorative belt, clip the motor wire of Z axis into the profile slot for Z axis.  
4. 连接2根Z轴电机线 5. 安装装饰带, 将Z轴电机线卡在Z轴型材槽里

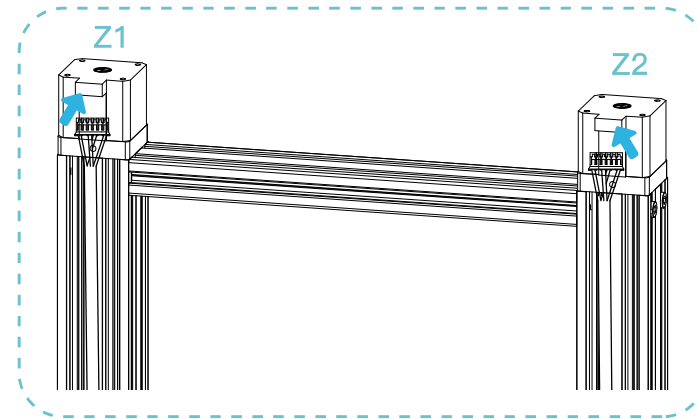
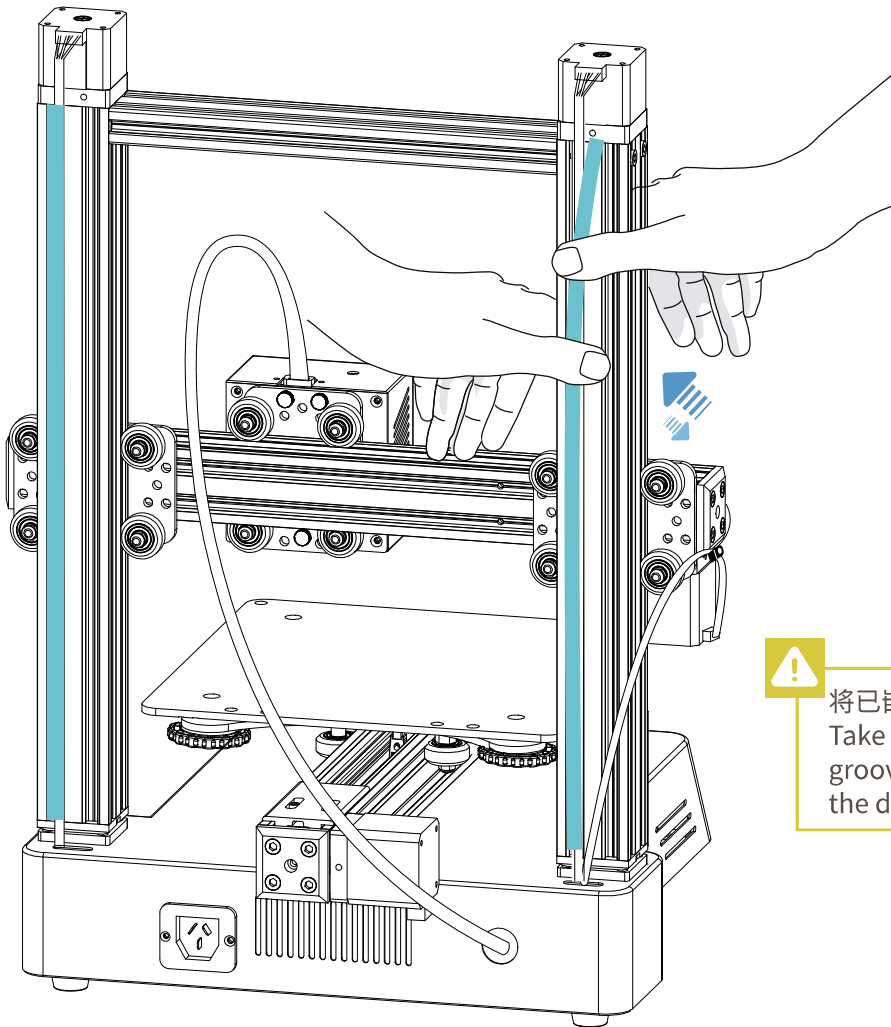

将已嵌入Z轴型材槽里的装饰带取出, 将Z轴电机线嵌入型材槽后装上装饰带  
Take out the decorative tape that has been inserted into the Z-axis profile groove, and insert the Z-axis motor wire into the profile groove and attach the decorative tape.

# 6

## Cable Connection 设备接线

6. Fix the signal cable with R clamp, M4\*8 Hexagon Socket Button Head Screws, M4T nut 7. Power connection  
6.用R型夹、M4×8内六角平圆头螺丝、M4T型螺母固定信号线7.接入电源



11 Power Cord x1  
电源线



19 M4\*8 Hexagon Socket x1  
Button Head Screws  
M4×8内六角平圆头螺丝



20 M4 T-Nut x1  
M4T型螺母



32 R Type Clamp x1  
R型线夹

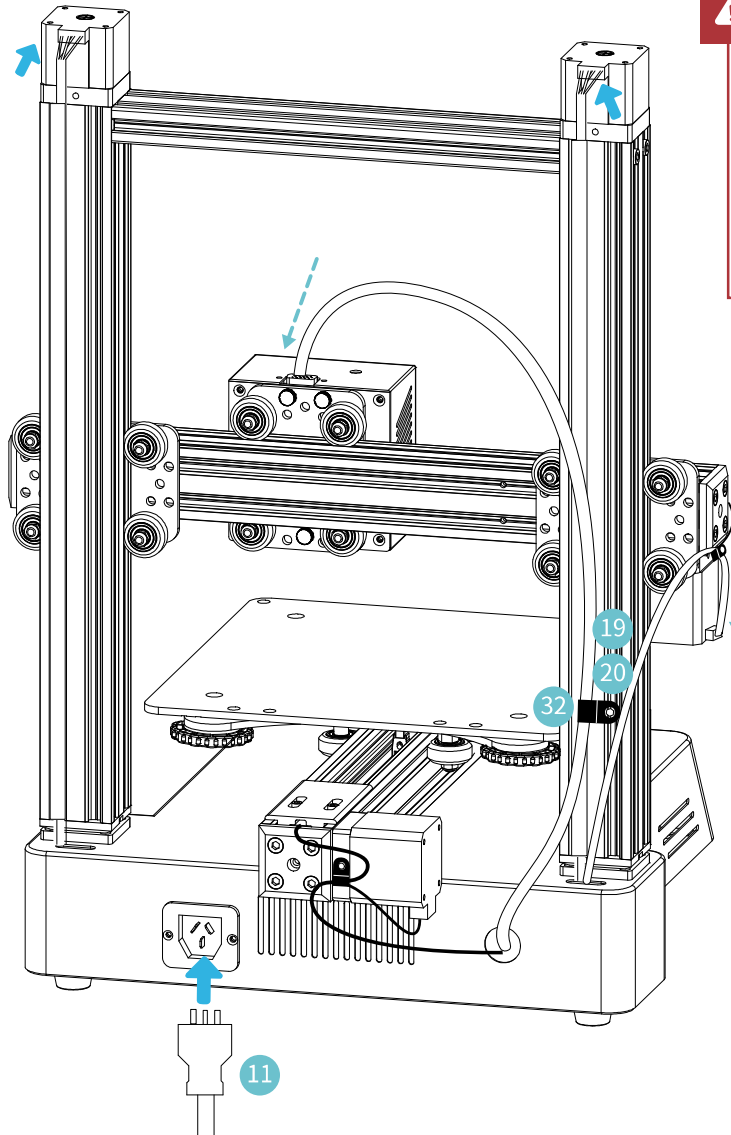

### Caution

- Select the correct input voltage to match your local mains (115/230V)
- Damage can occur if voltage is set incorrectly.
- Connect the power cord and turn the power switch to 1 to turn it on.
- Do not connect or disconnect the cables when the machine is powered on.
- 选择正确的输入电压以匹配您的本地电源 (115/230V)
- 如果电压设置不正确，可能会造成损坏。
- 连接电源线并将电源开关拨至1档即可开机
- 当机器通电时，请勿连接或断开连接线。

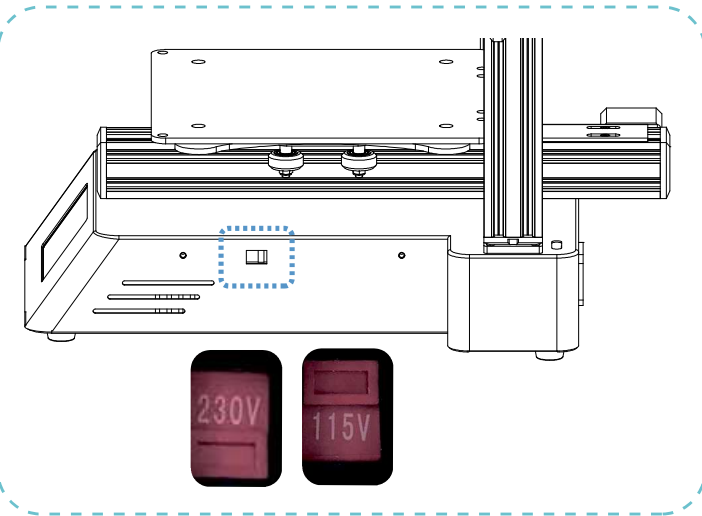

# 7

## Bed Leveling 调平平台

1. Tighten four leveling nuts at the bottom of the platform before initial leveling. 2. Select “Setting” →Leveling, clicking number ①/②/③/④/⑤

1.初次调平前，拧紧平台底部的四个调平螺母 2.选择设置→调平，点击数字①/②/③/④/⑤

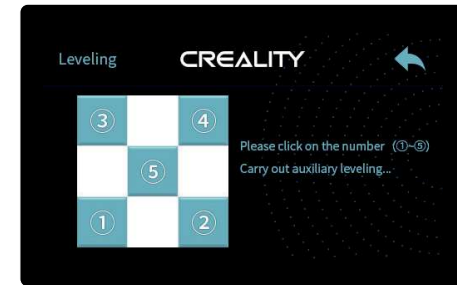
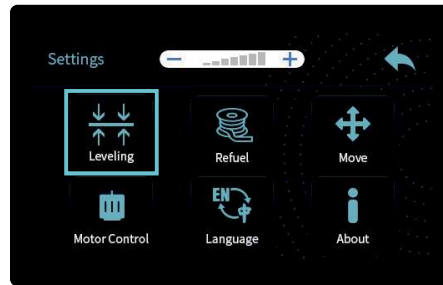

# 8

3. Move the nozzle the front/left leveling screw and adjust the platform height by turning the knob underneath (The thickness of a piece of A4 paper).
  4. Use a piece of A4 paper (standard printer paper) to assist with the adjustment, making sure that the nozzle lightly scratches the paper. Complete the adjustment of the screw on all 4 corners. Repeat above steps 1-2 times if necessary. Keep adjusting until there is slight resistance on the A4 paper from the nozzle.
  5. Click number ⑤ to test if the platform gap is proper. Repeat above steps once or twice if necessary
3. 移动喷嘴至螺丝上方附近。拧动螺丝，调节打印平台喷嘴使二者处于刚好贴合状态，间距约为0.1mm（一张A4纸的厚度）。
4. 我们可以利用一张A4纸辅助调平，使喷嘴刚好能在A4纸上产生划痕。依次完成四个边角上调平螺丝的调节。不断调整直到在拉动A4纸时能感受到来自喷嘴的轻微阻力。
5. 点击⑤，测试平台中间间隙是否合适，如有必要可重复上述步骤1-2次

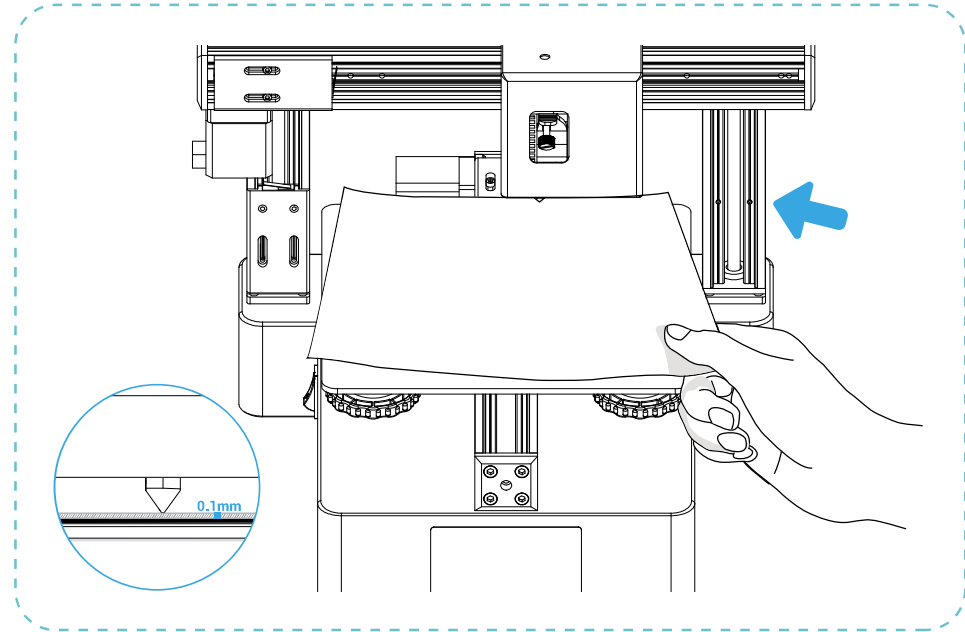
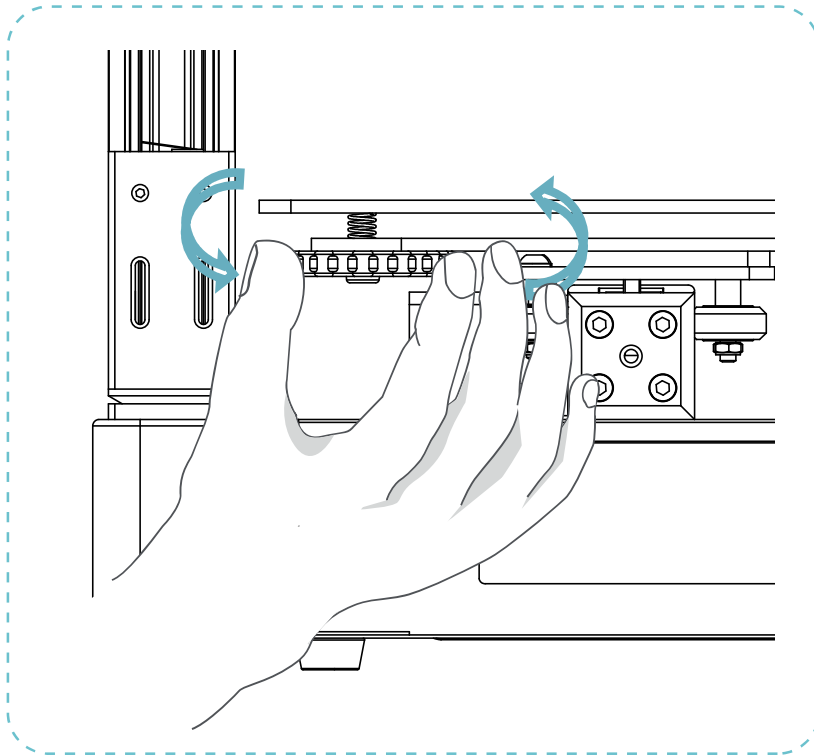

<p>The nozzle is too far away from the platform, so the consumables can not adhere to the platform. 喷嘴离平台太远，耗材无法粘附在平台上。</p>		
<p>Filament are extruded evenly, just sticking on the platform. 耗材挤出均匀，刚好贴在平台上。</p>		
<p>The nozzle is too close to the platform, and the filament are not extruded enough, even scraping the platform. 喷嘴离平台太近，耗材挤出不足，甚至刮坏平台。</p>		

# 9

## Preheating 预热

Method 1

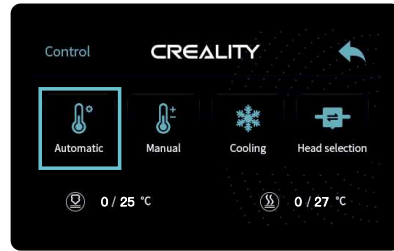
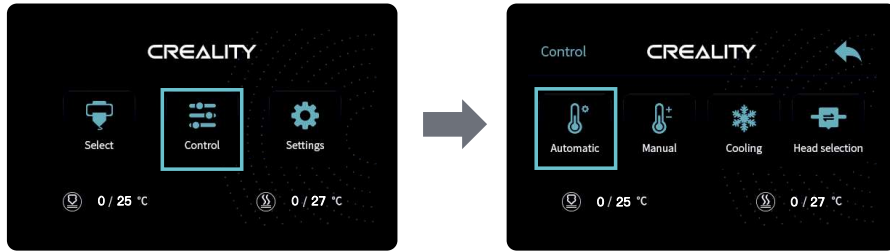

方法1



Method 2

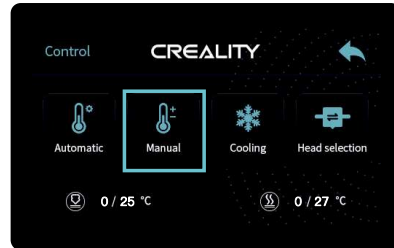

方法2

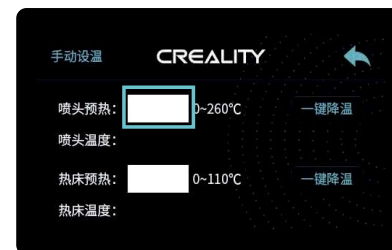
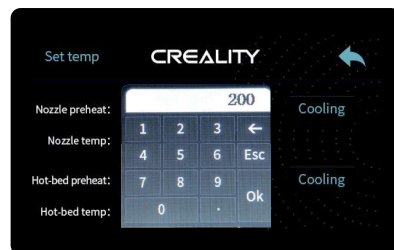
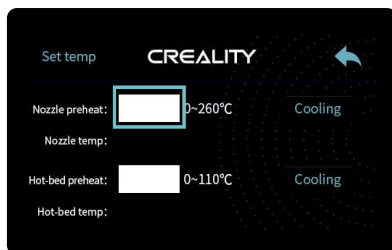

# 10

## Install The Rack 安装料架

Attach the Bracket with two M4\*8 Hexagon Socket Button Head Screws and two M4 T-Nut, Attach Spool Holder with included Nuts. When you wait for the temperature to rise, hang the filament over the Filament Holder

用2个M4×8内六角平圆头螺丝和2个M4T型螺母固定料架支撑，用尼龙螺母固定料管。当您等待温度上升时，把耗材挂在料架上。



9 Filament(200g) x1  
耗材 (200g)



21 Filament Holder x1  
料架



22 Filament Holder x1  
Tube with Nuts  
料管及螺母



19 M4\*8 Hexagon Socket x2  
Button Head Screws  
M4×8内六角平圆头螺丝



20 M4 T-Nut x2  
M4T型螺母

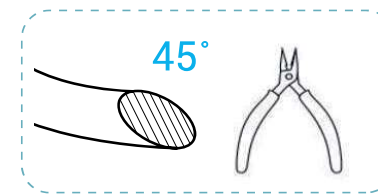
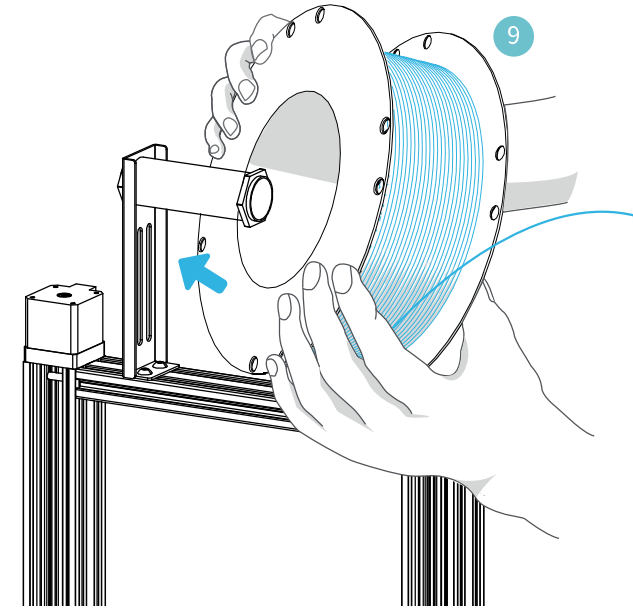
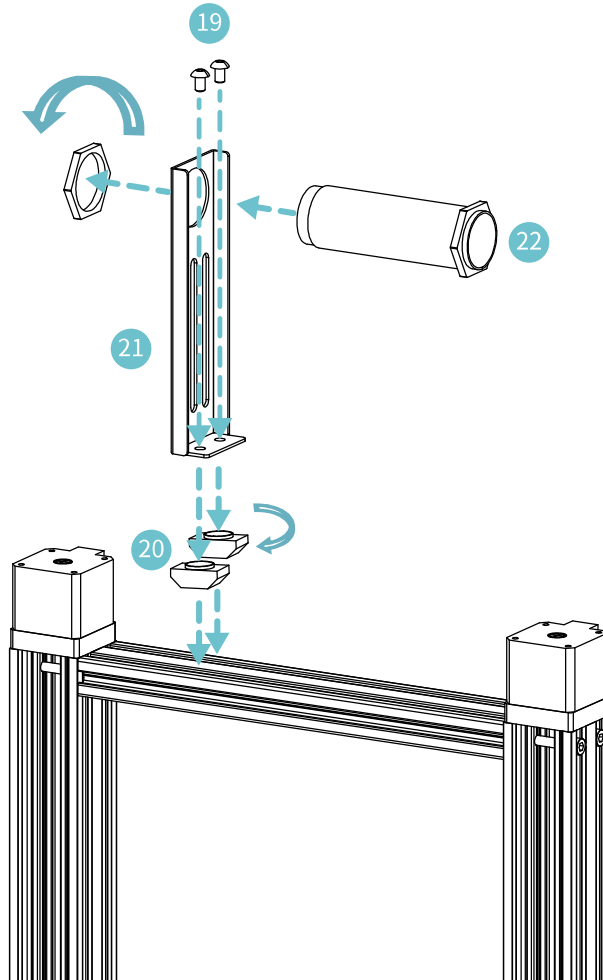

⚠ For smoother printing, the end of the filament should be placed as shown above.  
为了顺利完成打印, 耗材的末端位置应如图所示。



## 11

## Load Filament 装料

Insert the Teflon tube into the pneumatic joint. When the temporary temperature hits the target temperature, press and hold the extruding module's spring and feed in the filaments to the nozzle and keep await until you see liquid filament comes out of the nozzle. 将铁氟龙管插入快接头, 当前温度达到目标温度时, 按住挤出机弹簧, 将耗材插入挤出机小孔直至喷嘴位置, 等看到喷嘴处有耗材流出即表示耗材已经装载完成。

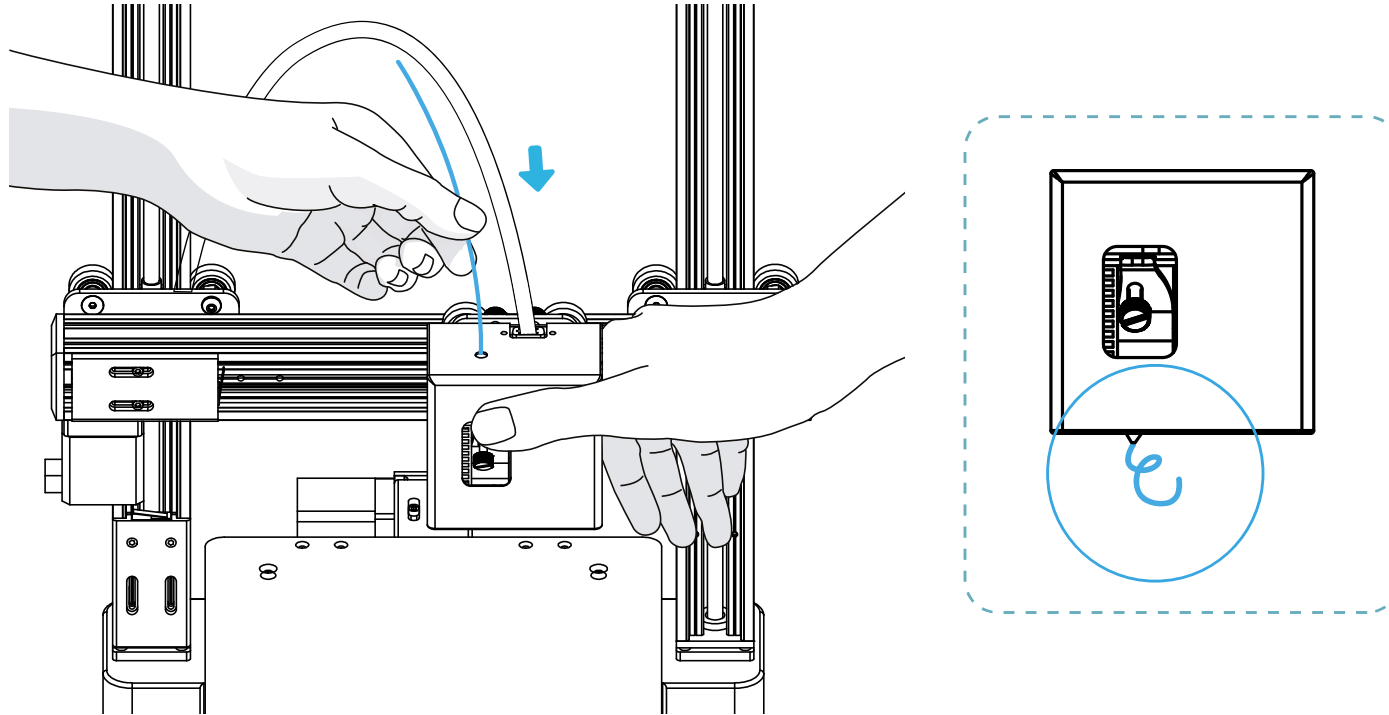

### Tips: How to Replace the Filament?

- 1、Cutting filament near the Extruder and slowly feed new filament until they are fed into the new filament.
- 2、Withdrawing the filament quickly and feeding the new filament after nozzle preheated and filament pushed a little forward.

Tips: 如何更换耗材?

方法一、在靠近挤出机处将耗材剪断, 将新耗材缓缓送入, 直到耗材被送入导料管为止。

方法二、预热喷嘴后, 将耗材往前推进一下后, 迅速抽出耗材, 将新耗材送入。

# 12

## Start Printing

开始打印



1. Double click to install the software. | 安装软件

2. Double click to open the software. | 打开软件

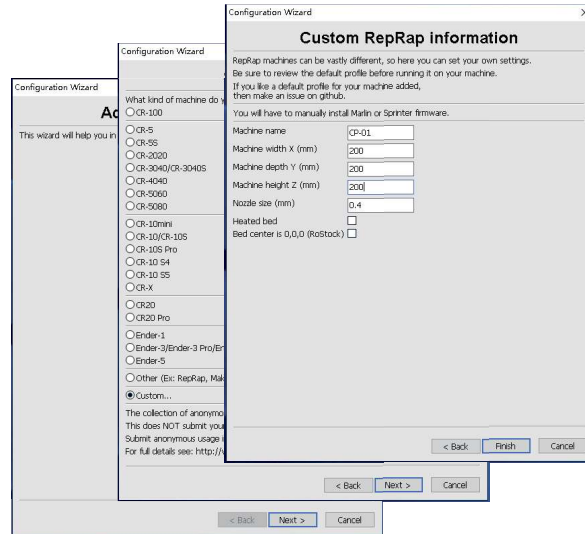

3. Select language→Next→Select your machine→Next→Finish.

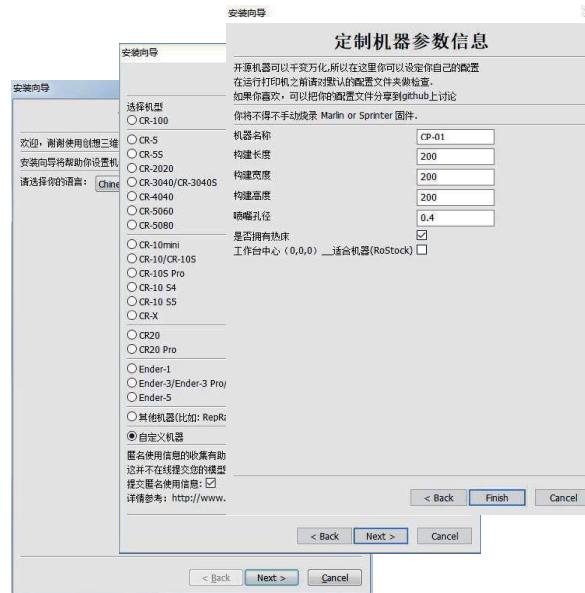

3. 依次选择语言→Next→选择对应机型→Next→Finish, 完成设置.



4. Open the software→Load→Select the file→Wait for slicing to finish  
打开创想三维切片软件→Load (读取文件)→选择文件

# 13

## Start Printing

开始打印

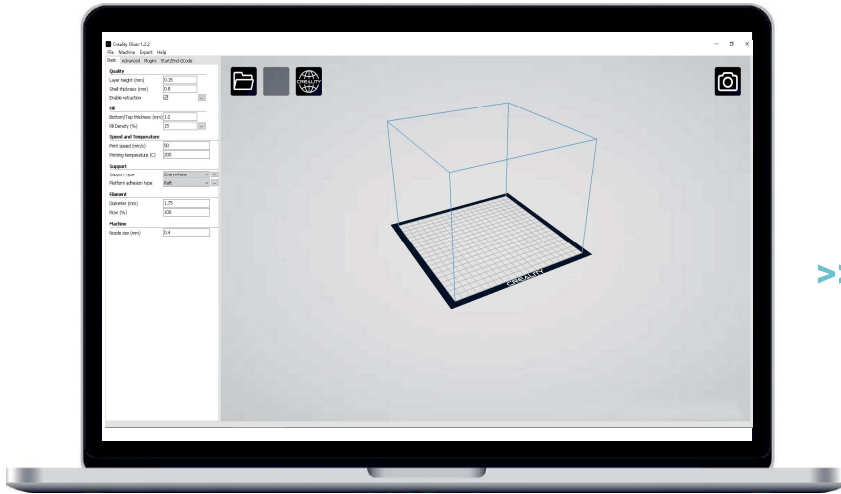

5. Generate G-code, and save the gcode file to TF card.  
生成 G 代码→保存

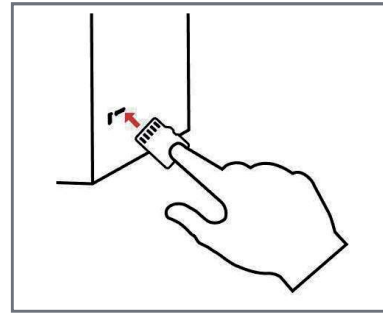

6. Insert the Storage Card → Select “Procedure Selection” → Select file in the Storage card → Print  
插入存储卡→程序选择→存储卡的文件→开始打印

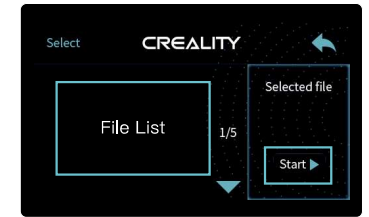

File names must be Latin letters or numbers, not Chinese characters or other special symbols  
文件名需为拉丁字母或数字, 不能为汉字或其他特殊符号



Notes: For details on the software instructions, please refer to the slicing software manual in the memory card!  
温馨提示: 软件使用说明详情, 请见存储卡内切片软件使用手册!

# 14

## Transform into a Laser Engraver 改装成激光雕刻机

1. Use to (jog mode) move the 3D Printing Module to the illustrated position. 1.使用(点动模式)将3D打印模组移动到图示位置。

Click "Setting" → "Move" → Click "Z+ / Z-" to move the Z axis, with a gap of 60-80mm between machine head and the upper surface of workpiece  
点击“设置”→“移动轴”→点击“Z+/Z-”使Z轴移动,机头距离平台表面60-80mm

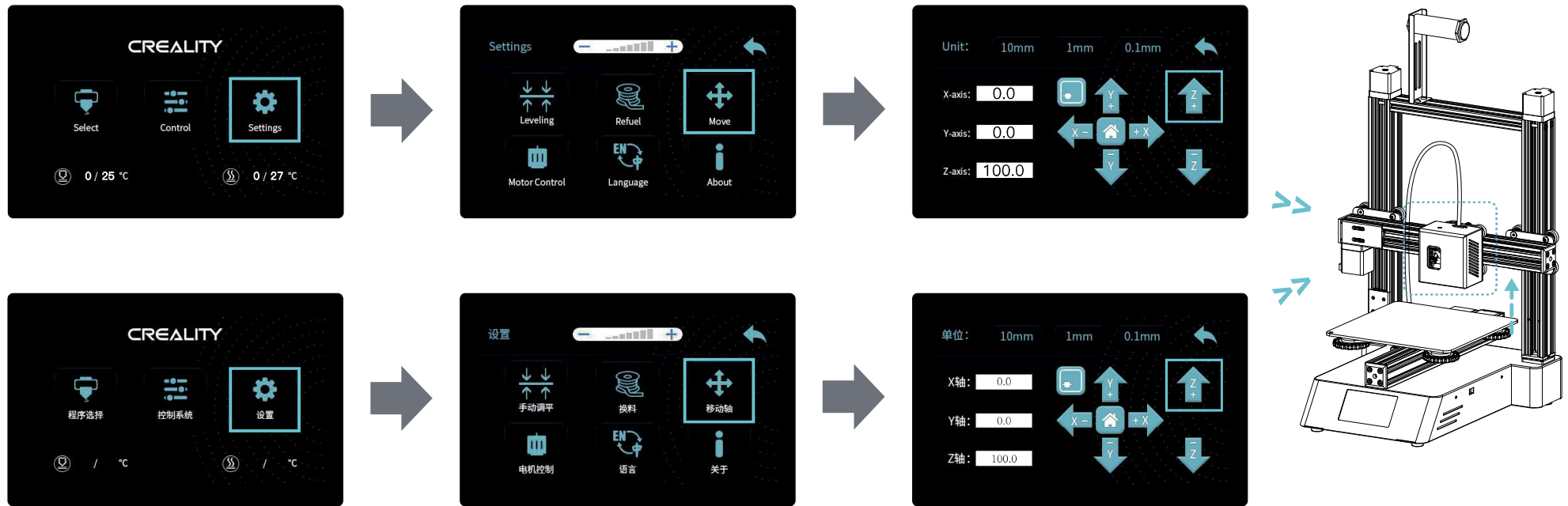

# 15

## Transform into a Laser Engraver 改装成激光雕刻机

- 2.Pull out the signal cable, remove the 3 screws, replace the laser engraving head, fix the laser module to the X axis and insert the signal cable.  
2.拔出信号线, 拆下3颗螺丝, 更换激光雕刻头, 将激光模组固定到 X 轴并插入信号线。



- 5 Laser Machine Head x1  
激光雕刻头



- 17 M4\*8 Hand Twist Nut x3  
M4\*8手拧螺丝



- 18 M4\*8 Hexagon Socket Cap Screws x3  
M4\*8内六角圆柱头螺丝

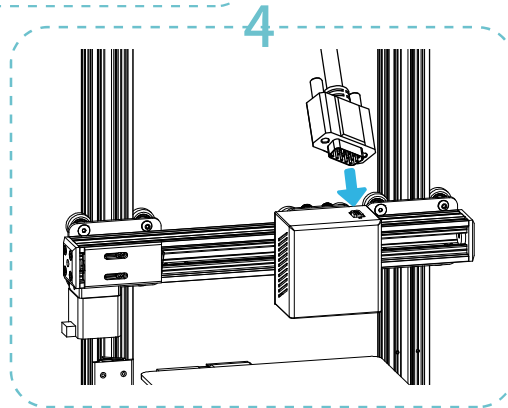
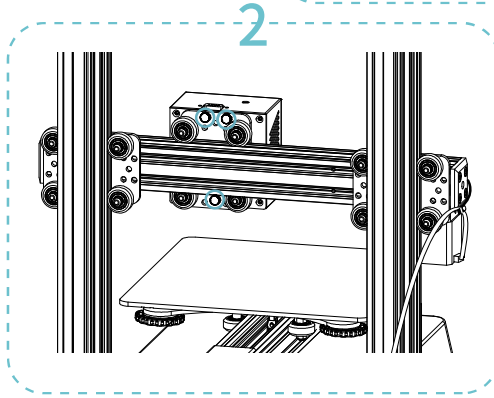
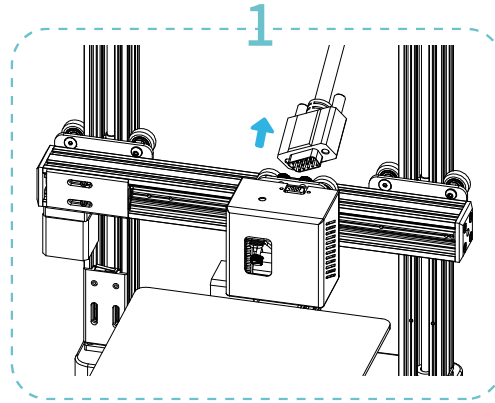

**Caution**  
Please turn off the power and disconnect the power before operation.  
操作前请先关机, 并断开电源

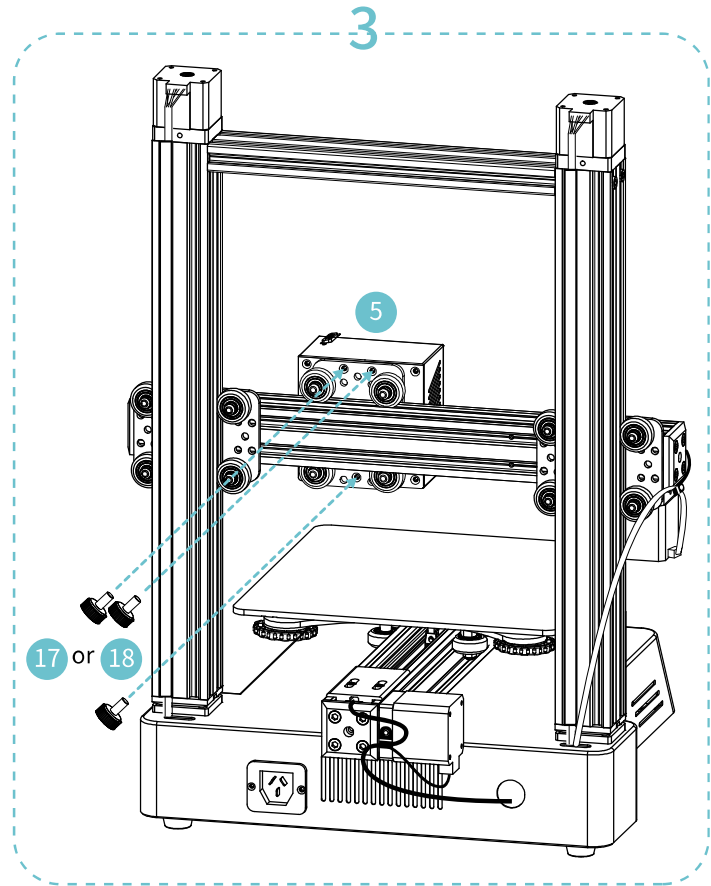

# 16

## Transform into a Laser Engraver 改装成激光雕刻机

3. Click "Control" → Click "Machine head selection" → Select laser machine head (no need to return to home)
3. 点击“控制系统” → 点击“机头选择” → 选择激光机头 (不需要回原点)

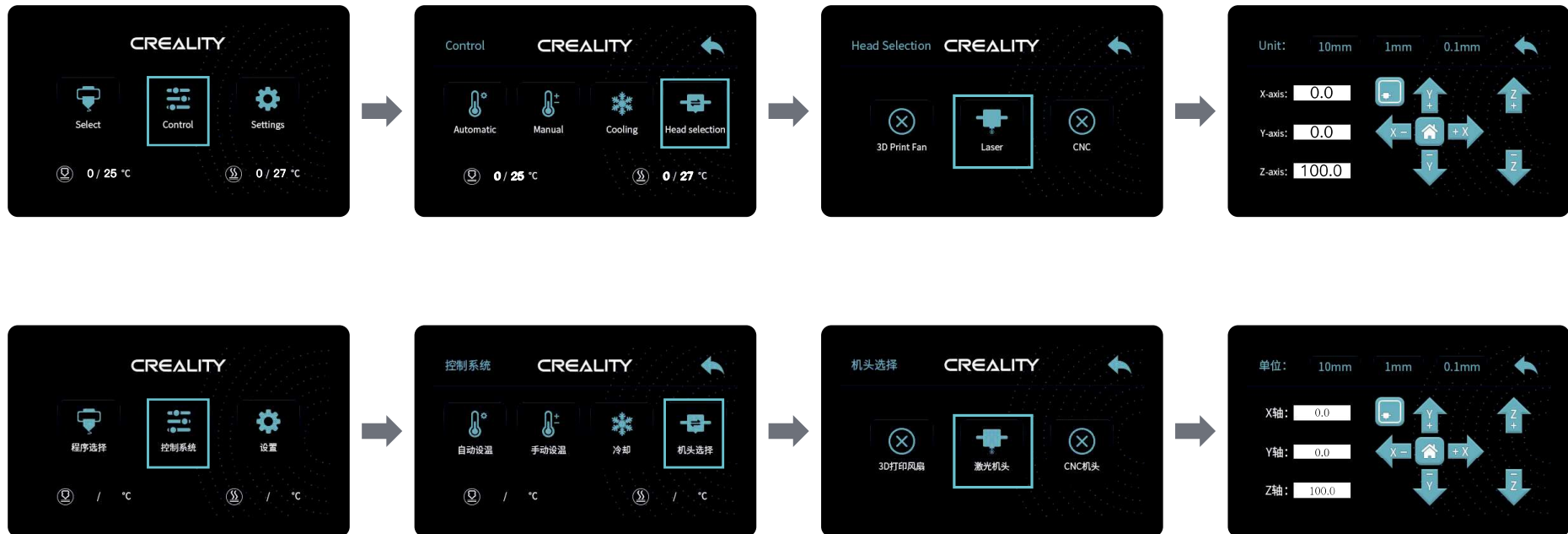

Click "Z + / Z-" to move the Z axis, with a gap of 60-80mm between machine head and the upper surface of workpiece  
点击“Z+/Z-”使Z轴移动, 机头距离工件上表面60-80mm

# 17

## Transform into a Laser Engraver 改装成激光雕刻机

4.Place the material , Immobilize the material

4.放置材料,固定材料



8 Board x1  
木板



Non-standard  
非标配

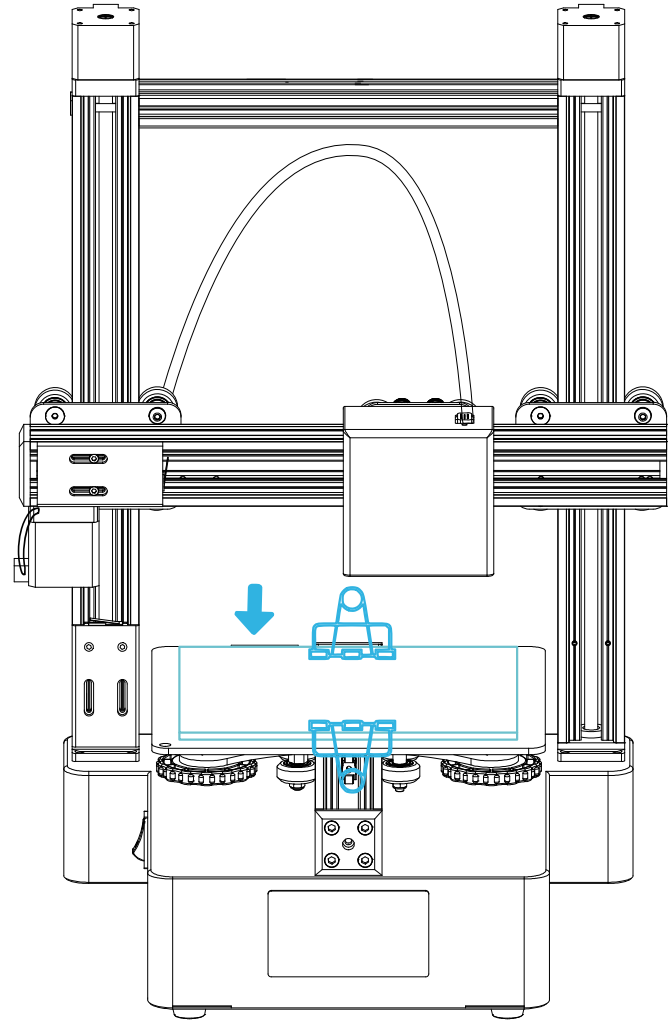

**Tips:**1.Please make sure to take safety precautions against accidents

2.Make sure the fixtures and binder clips don't impede the movement of the linear modules.

温馨提示: 1.请务必做好安全防护措施,以免造成意外

2.确保压块不会妨碍直线模組的运动

# 18

## Laser Head Focusing 激光头对焦

Turn the knob to adjust focal length until a focal point appears on the wood plate → Double click  to position  
旋转旋钮调整焦距，直至木板上的焦点聚拢 → 双击  进行定位

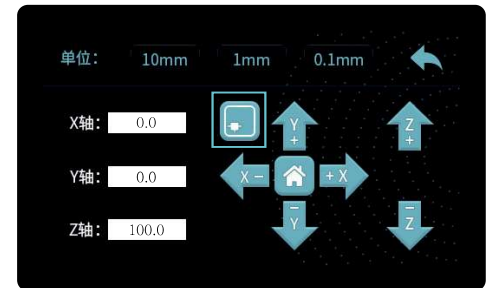
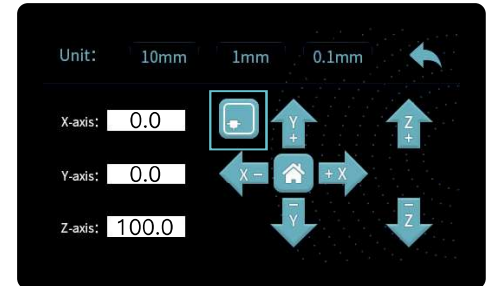
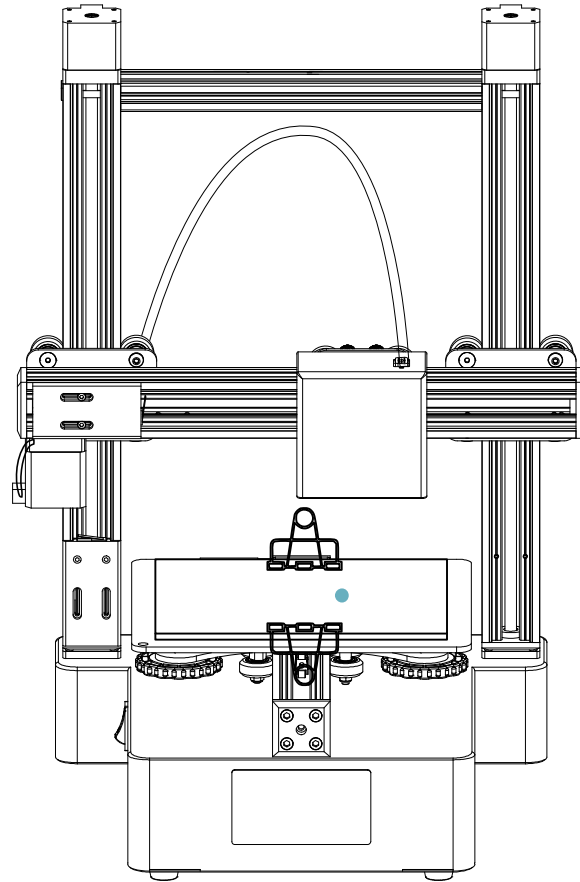
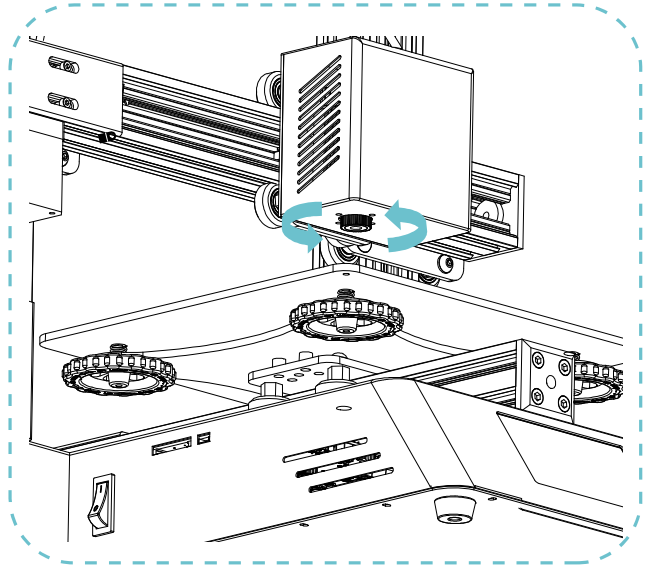

31 Laser Safety Goggles x1  
激光防护眼镜



### Tips 温馨提示

1. Please wear laser goggles in advance to protect yourself from laser damage during your operation.
2. Please operate safely, to prevent yourself from touching the running laser printing head and laser irradiation range to get injured.

1操作过程中，提前戴好激光护目镜，避免激光伤害

2请安全操作，避免触碰工作中的激光打印头及激光照射范围，以免受伤。



# 19

## Start Laser Engraving 开始激光雕刻

1. Double click to install the software. | 安装软件
2. Double click to open the software. | 打开软件

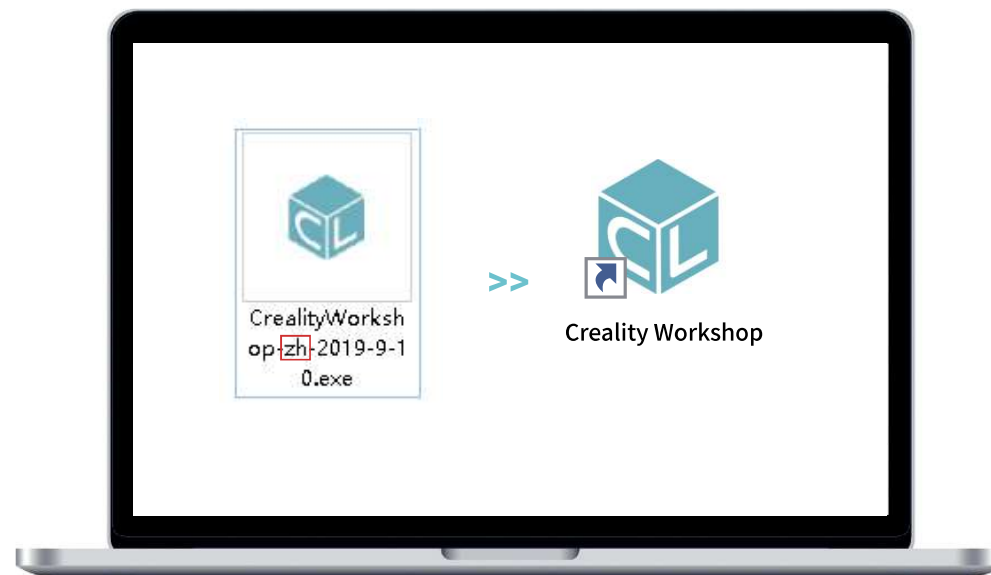
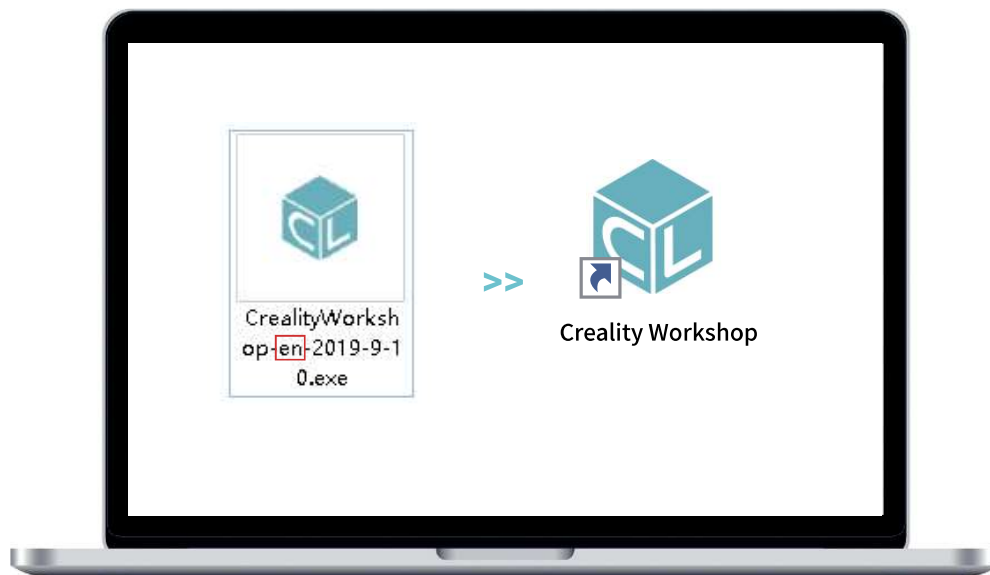

Notes: For details on the software instructions, please refer to the slicing software manual in the memory card!

温馨提示: 软件使用说明详情, 请见存储卡内切片软件使用手册!

# 20

## Start Laser Engraving 开始激光雕刻

Open CreativityWorkshop → Select Laser Engraving → Insert image → Generate bool → Save into Storage Card.

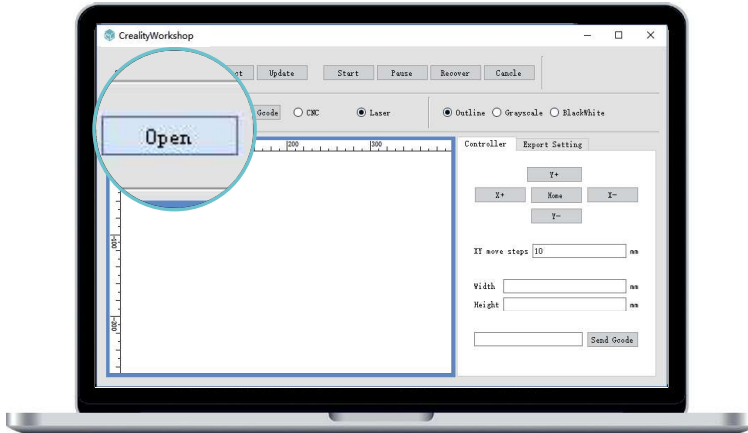

1. Select the print mode and click "Open".

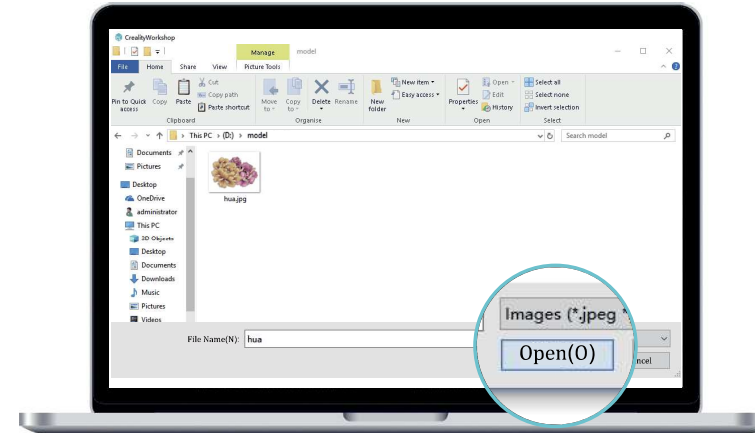

2. Select the file you want to print, and "Open".

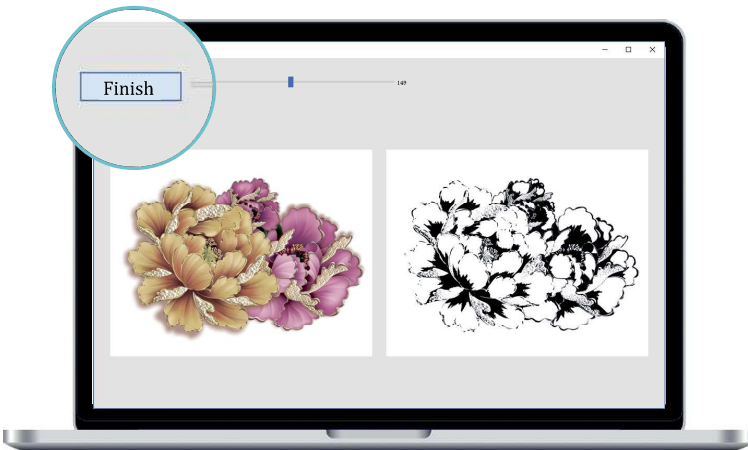

3. Adjust the binary value to your satisfied size, and click "Finish".

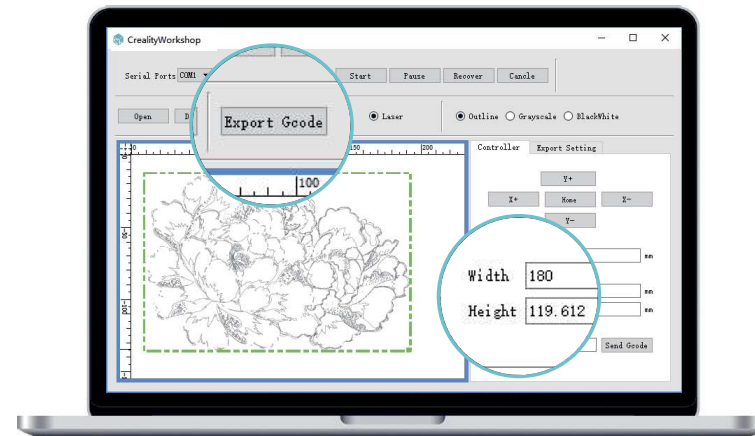

4. Adjust the width and height within printer's printing size. click "Export Gcode" to export the printing file.

# 21

## Start Laser Engraving 开始激光雕刻

打开CrealityWorkshop软件→选择“激光”切片,插入图像→生成刀路→保存(保存到存储卡)

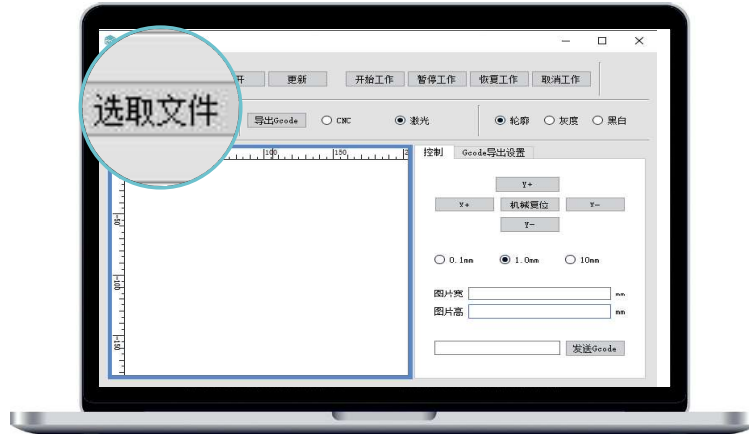

1.选择打印模式,单击“选取文件”。

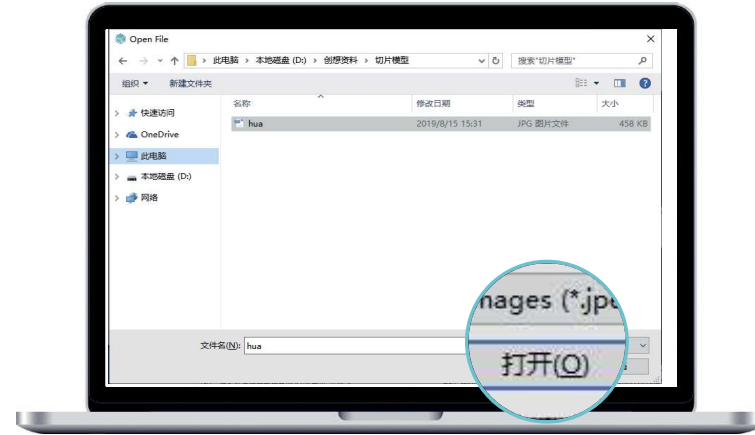

2.选择需要打印的文件,并“打开”。

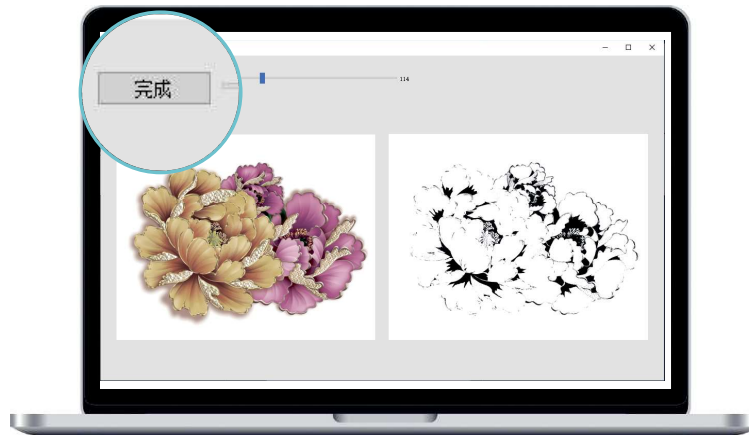

3.把二值化数值调整到满意的大小,点击“完成”。



4.把“图片宽”、“图片高”调整打印机打印范围内,点击“导出Gcode”,导出打印文件。

# 22

## Start Laser Engraving 开始激光雕刻

6.Insert the Storage Card → Select “Procedure Selection” → Select file in the TF card → Start Laser Engraving  
插入存储卡→程序选择→存储卡的文件→开始激光雕刻

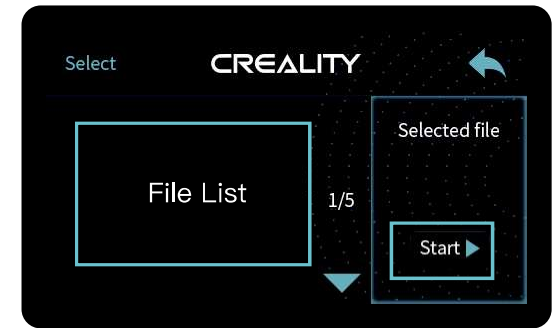
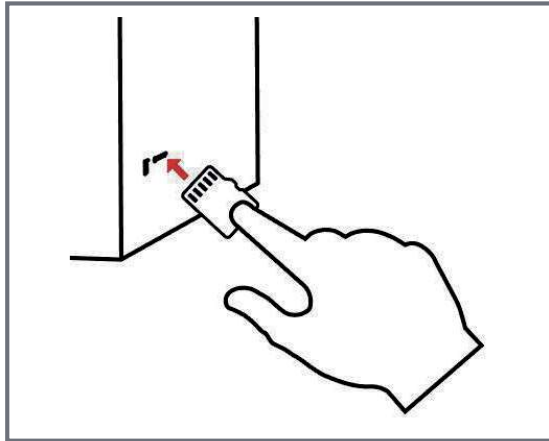

# 23

## Transform into a CNC Engraver 改装成CNC雕刻机

1. Pull out the signal cable, remove the 3 screws, replace the CNC engraving head, fix the laser module to the X axis and insert the signal cable.  
1. 拔出信号线, 拆下3颗螺丝, 更换CNC雕刻头, 将激光模组固定到 X 轴并插入信号线。



6 CNC Machine Head ×1  
CNC雕刻头



17 M4\*8 Hand Twist Nut ×3  
M4\*8手拧螺丝



18 M4\*8 Hexagon Socket Cap Screws ×3  
M4×8内六角圆柱头螺丝

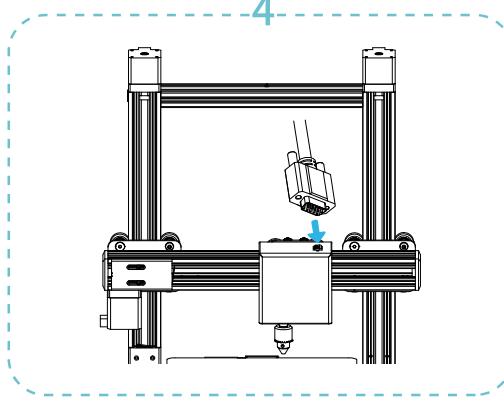
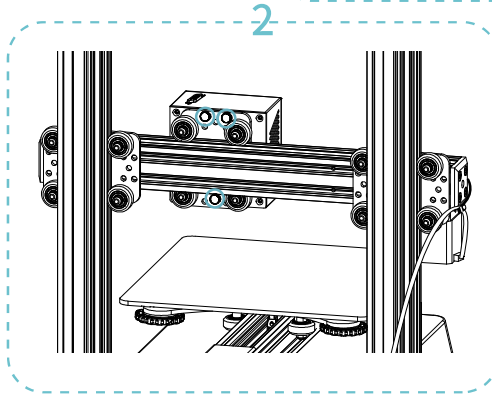
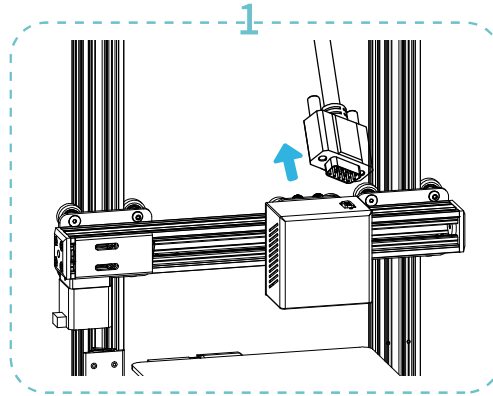

### Caution

Please turn off the power and disconnect the power before operation.  
操作前请先关机, 并断开电源

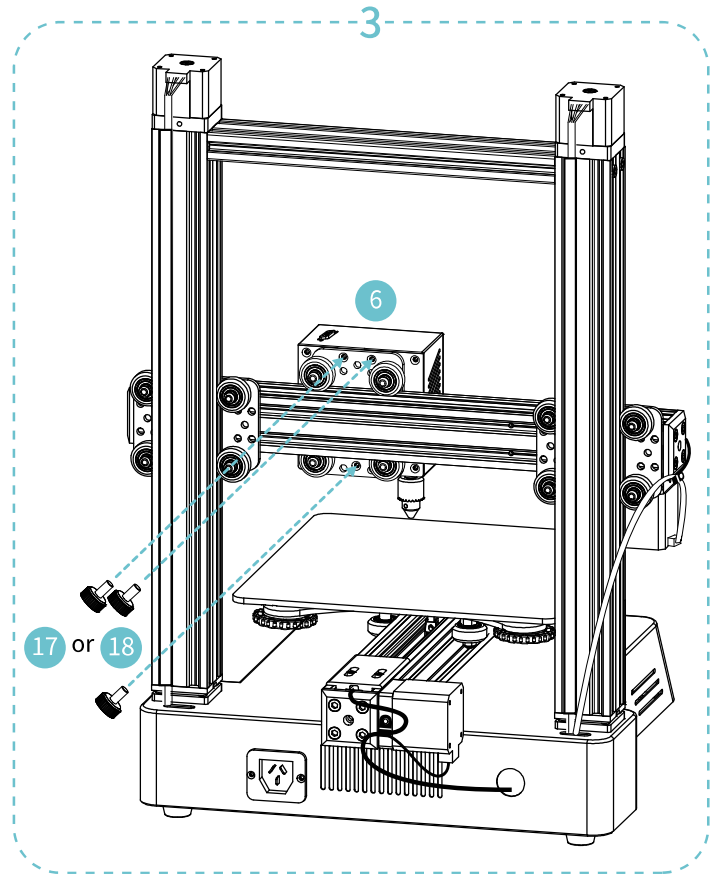

# 24

## Transform into a CNC Engraver 改装成CNC雕刻机

2. Click "Control" → Click "Machine head selection" → Select CNC machine head (no need to return to home)

2. 点击“控制系统” → 点击“机头选择” → 选择CNC机头 (不需要回原点)

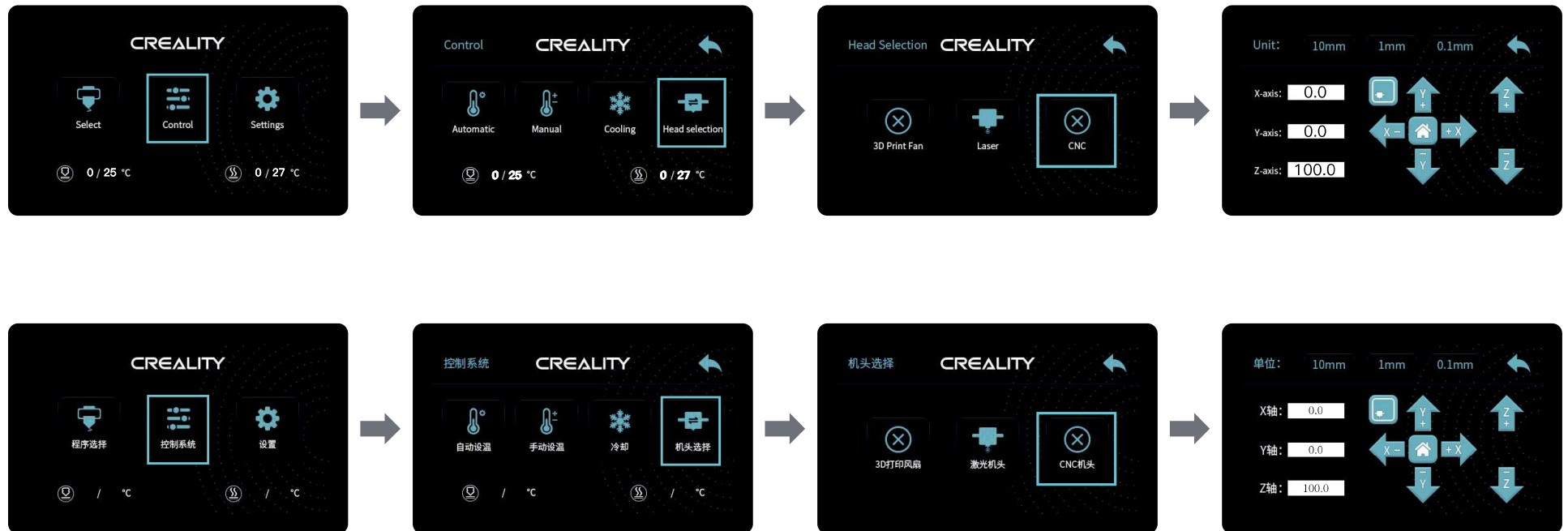

# 25

## Transform into a CNC Engraver 改装成CNC雕刻机

3.Remove the silicon carbon crystal glass on the platform 4.Installation of engraving platform 5.Place the material,Immobilize the material  
3.将平台上硅碳晶玻璃拆下 4.安装雕刻平台 5.放置材料,固定材料

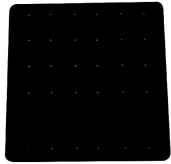

3 Carving Platform x1  
雕刻平台

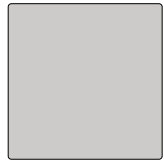

7 Acrylic sheet x1  
亚克力板



24 A&B Code x4  
A、B码仔



23 M4\*50 Hexagon Countersunk Head Screw x4  
M4\*50内六角沉头螺丝



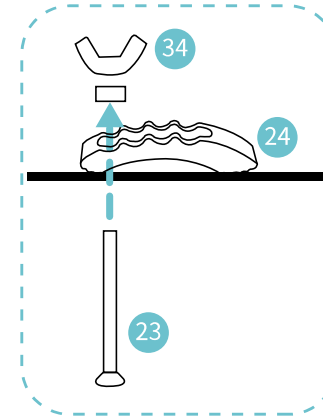
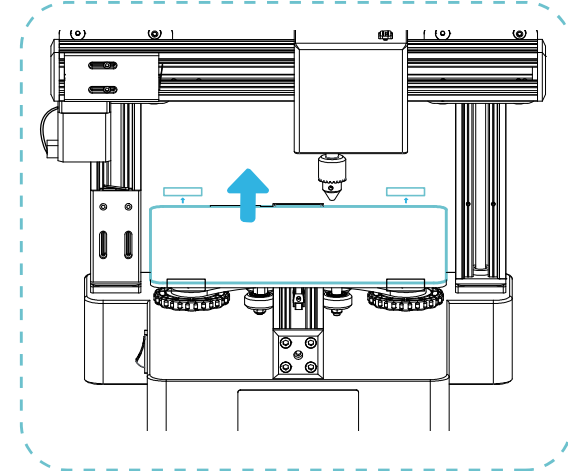
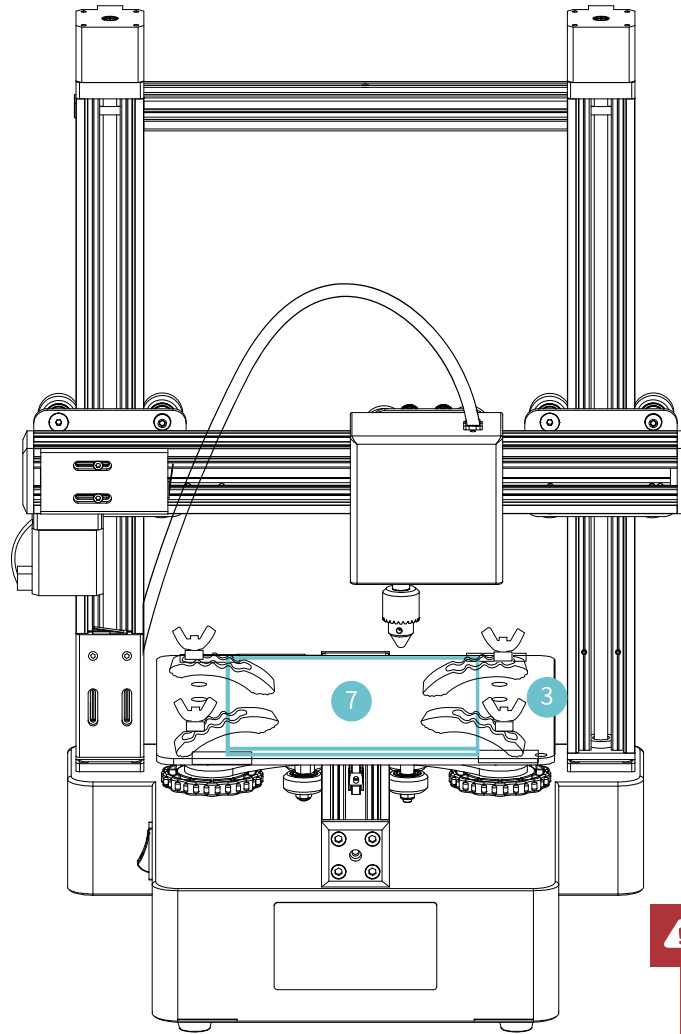

34 M4 butterfly nut x4  
M4蝶型螺母



**Tips:** 1.If you install four A&B codes, the actual printing volume will be smaller than the maximum size.  
2.Please make sure to take safety precautions against accidents  
温馨提示: 1.安装四个码仔之后,实际雕刻尺寸达不到最大尺寸  
2.请务必做好安全防护措施,以免造成意外

# 26

## Transform into a CNC Engraver 改装成CNC雕刻机

6. Attach the CNC Engraving Tools , Move Z axis downward in 10mm, 1mm and 0.1mm until the drill just touches the platform, double click  to position  
 6.固定铣刀到CNC模组上, 向下移动Z轴, 依次用10mm,1mm,0.1mm进行移动, 使钻头刚好接触到平台, 双击  进行定位



29 Versatile Wrench x1  
多功能小扳手



33 Engraving Tools x1  
铣刀



25 CNC Safety Goggles x1  
CNC防护眼镜

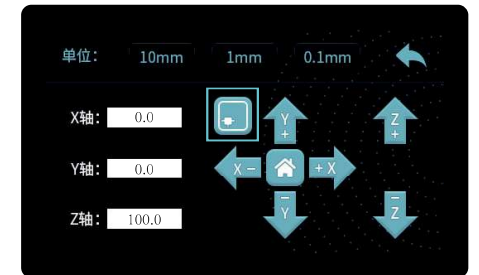
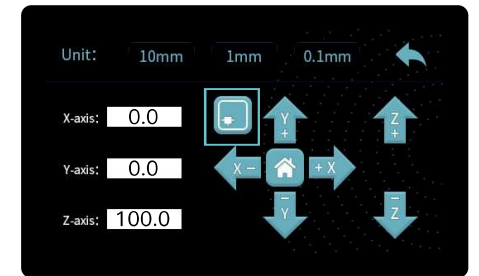
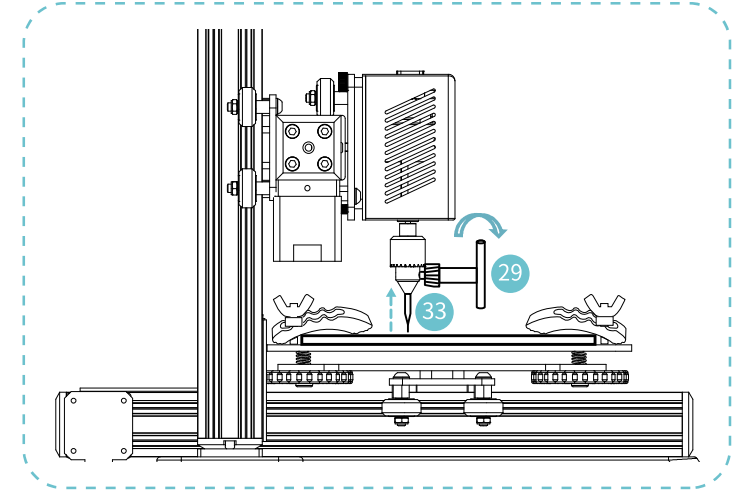
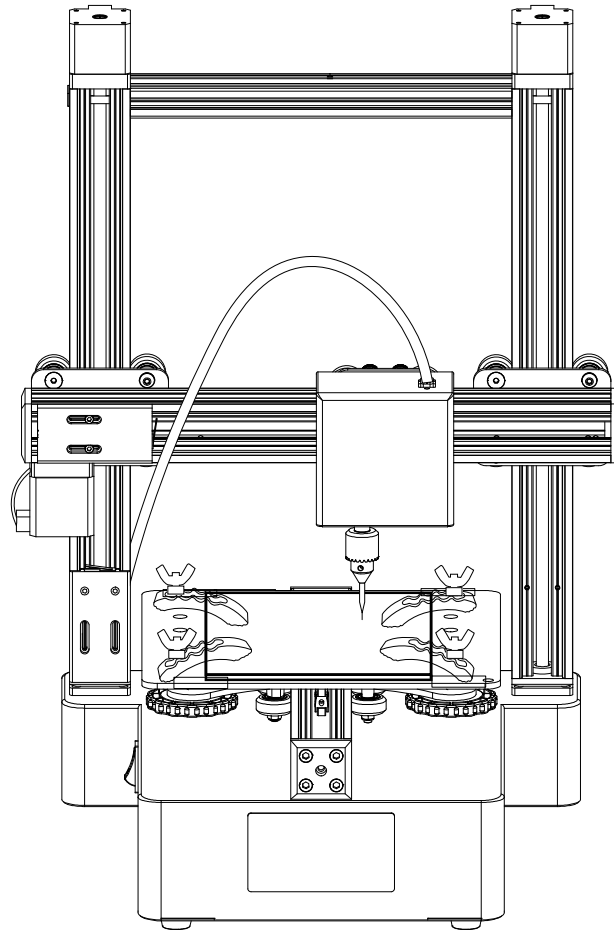

**Tips:** 1. Drill of CNC machine head rotates at a high speed. Please move Z axis up for a certain height to avoid the occurrence of the drill damaging machine parts.  
 2. Please wear CNC goggles to protect yourself from injury during your operation  
 3. Please use a multi-function wrench to fix the cutter to avoid falling off during printing  
 温馨提示: 1.选择CNC机头后钻头会高速旋转, 请务必先将Z轴抬起适当高度, 避免钻头损坏机器部件  
 2.操作过程中, 请戴好CNC护目镜, 做好安全防护, 以免造成意外  
 3.请使用多功能小扳手固定好铣刀, 避免打印过程中脱落



# 27

## Start CNC Engraving 开始CNC雕刻

Open CreativityWorkshop → Select CNC Engraving → Insert image → Generate bool → Save into Storage Card.

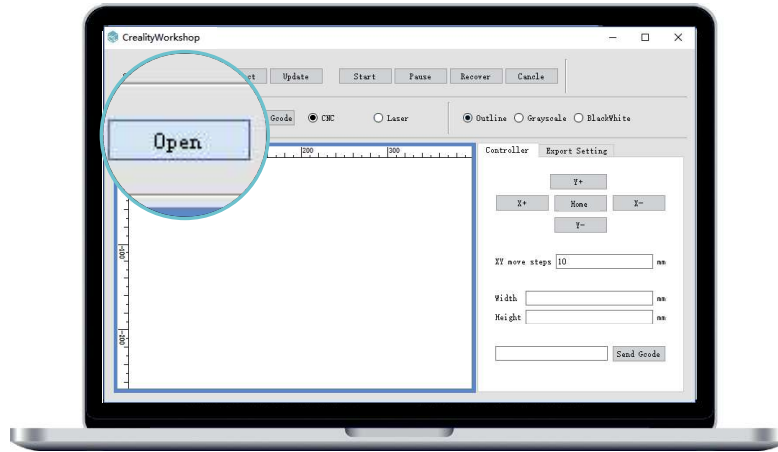

1. Click "Open".

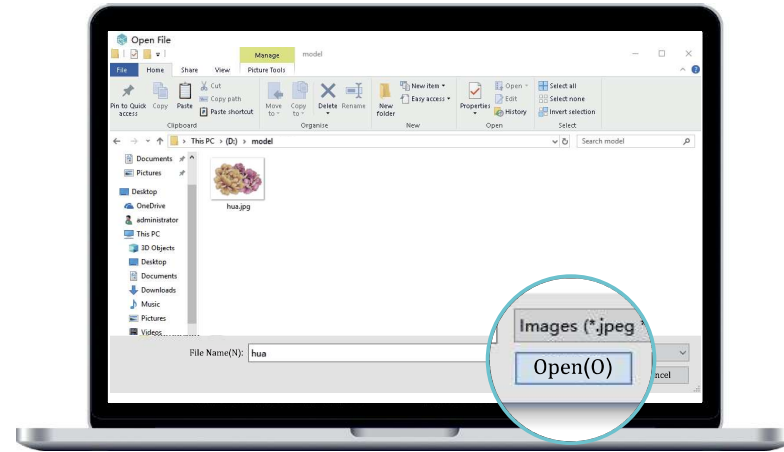

2. Select the file you want to print, and "Open".

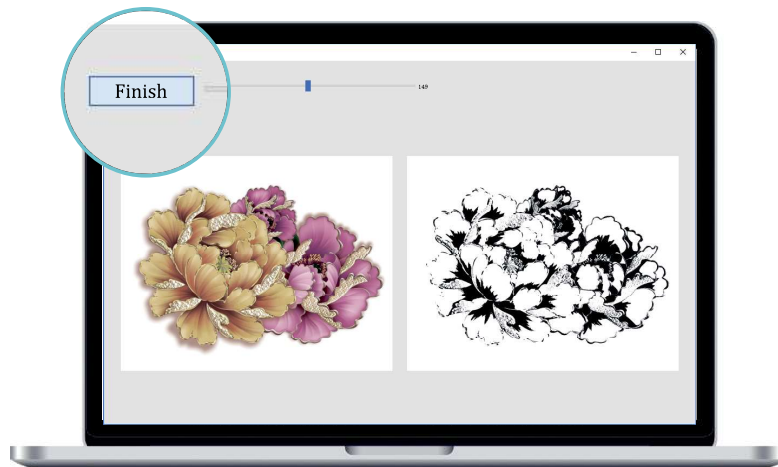

3. Adjust the binary value to your satisfied size, and click "Finish".

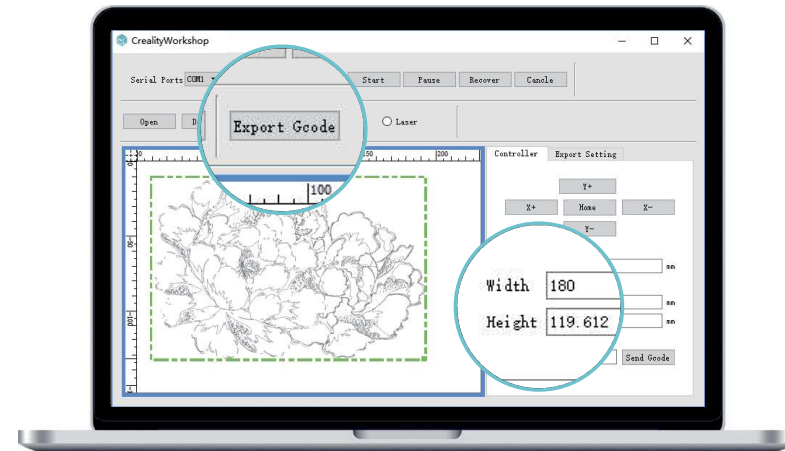

4. Adjust the width and height within printer's printing size. click "Export Gcode" to export the printing file.

# 28

## Start CNC Engraving 开始CNC雕刻

打开CrealityWorkshop软件→选择“CNC”切片，插入图像→生成刀路→保存(保存到存储卡)

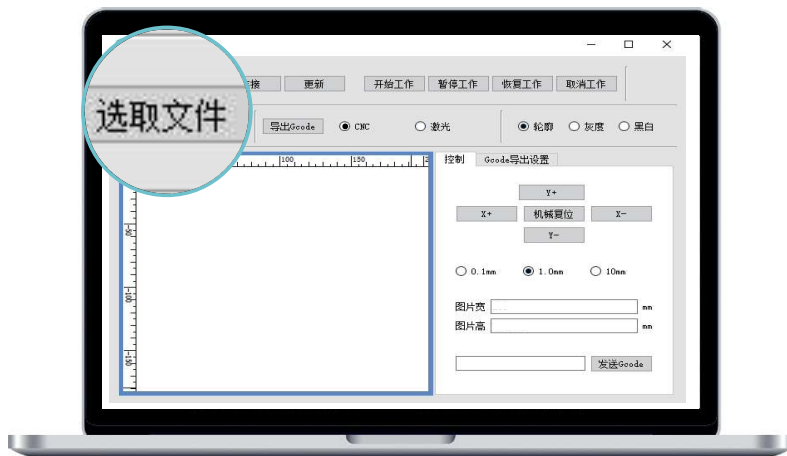

1.单击“选取文件”。

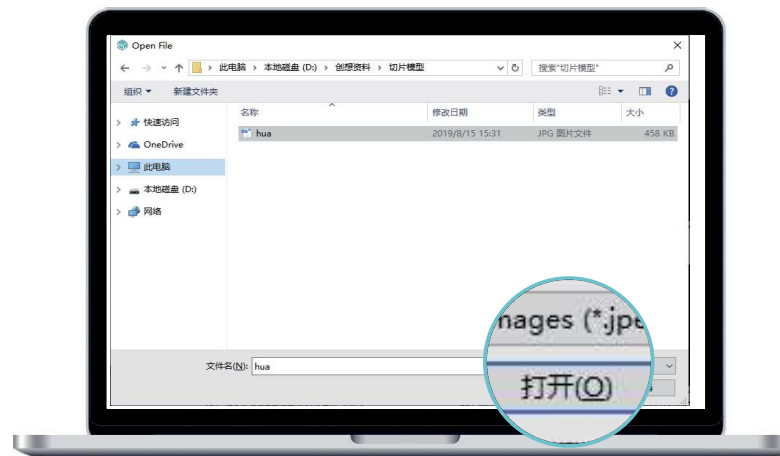

2.选择需要打印的文件，并“打开”。

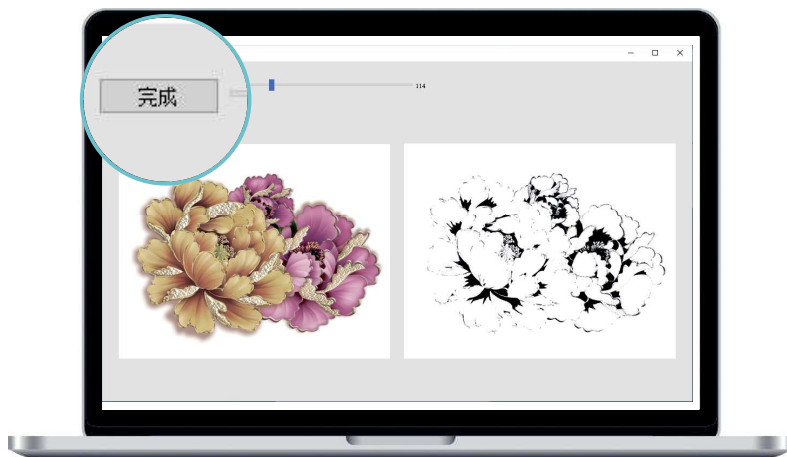

3.把二值化数值调整到满意的大小，点击“完成”。



4.把“图片宽”、“图片高”调整打印机打印范围内，点击“导出Gcode”，导出打印文件。

# 29

## Start CNC Engraving 开始CNC雕刻

6.Insert the Storage Card → Select “Procedure Selection” → Select file in the Storage card → Start CNC Engraving

插入存储卡→程序选择→存储卡的文件→开始CNC雕刻

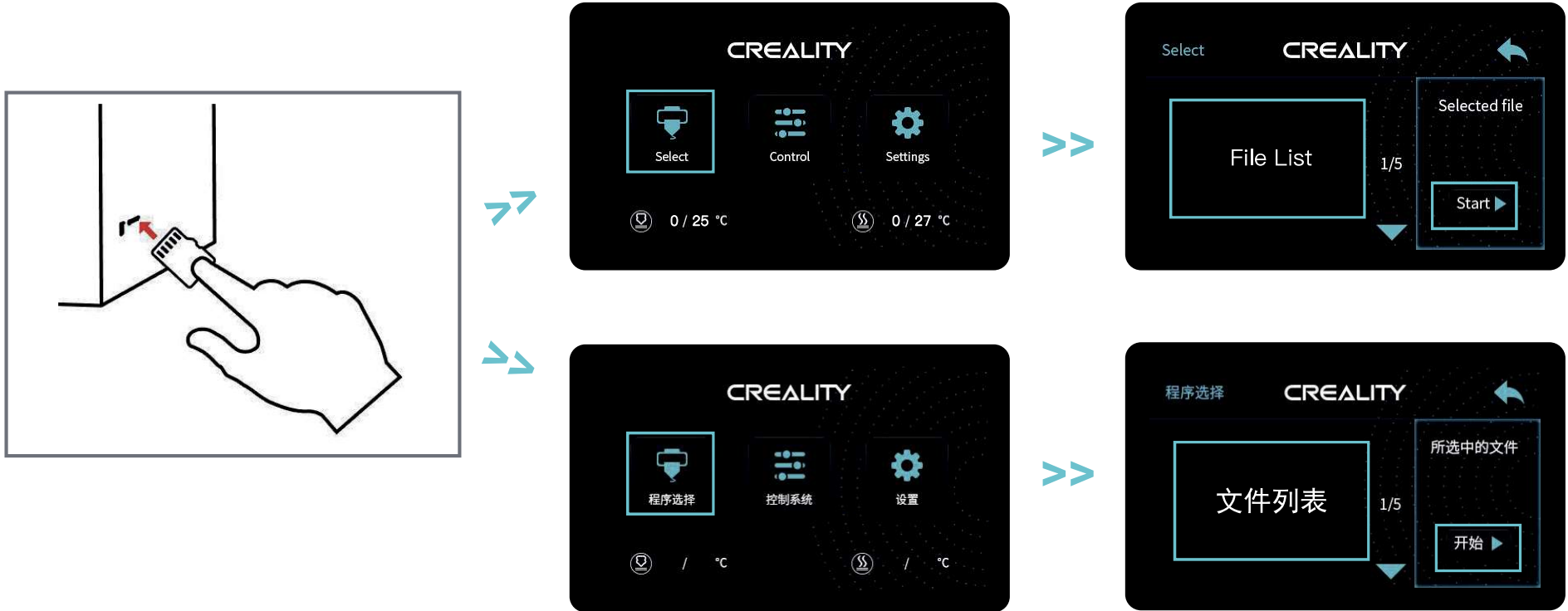

**Tips:** 1. Drill of CNC machine head rotates at a high speed. Please move Z axis up for a certain height to avoid the occurrence of the drill damaging machine parts .  
2. Please wear CNC goggles to protect yourself from injury during your operation  
温馨提示: 1.选择CNC机头后钻头会高速旋转, 请务必先将Z轴抬起适当高度, 避免钻头损坏机器部件 2.操作过程中, 戴好CNC护目镜, 做好安全防护, 以免造成意外

# Circuit Wiring

电路接线

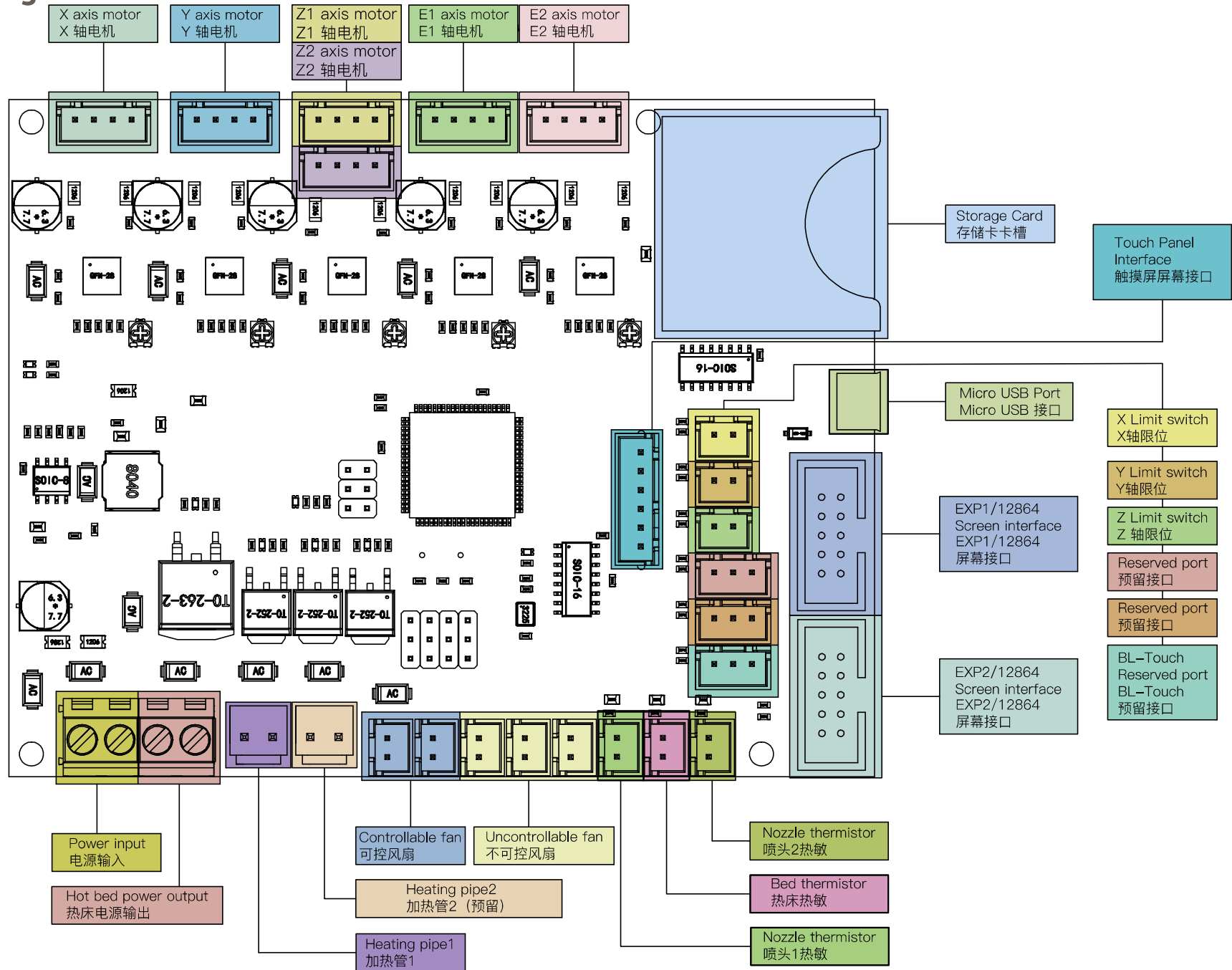

# Hot Swap Adapter Plate Circuit Wiring

热拔插转接板电路接线

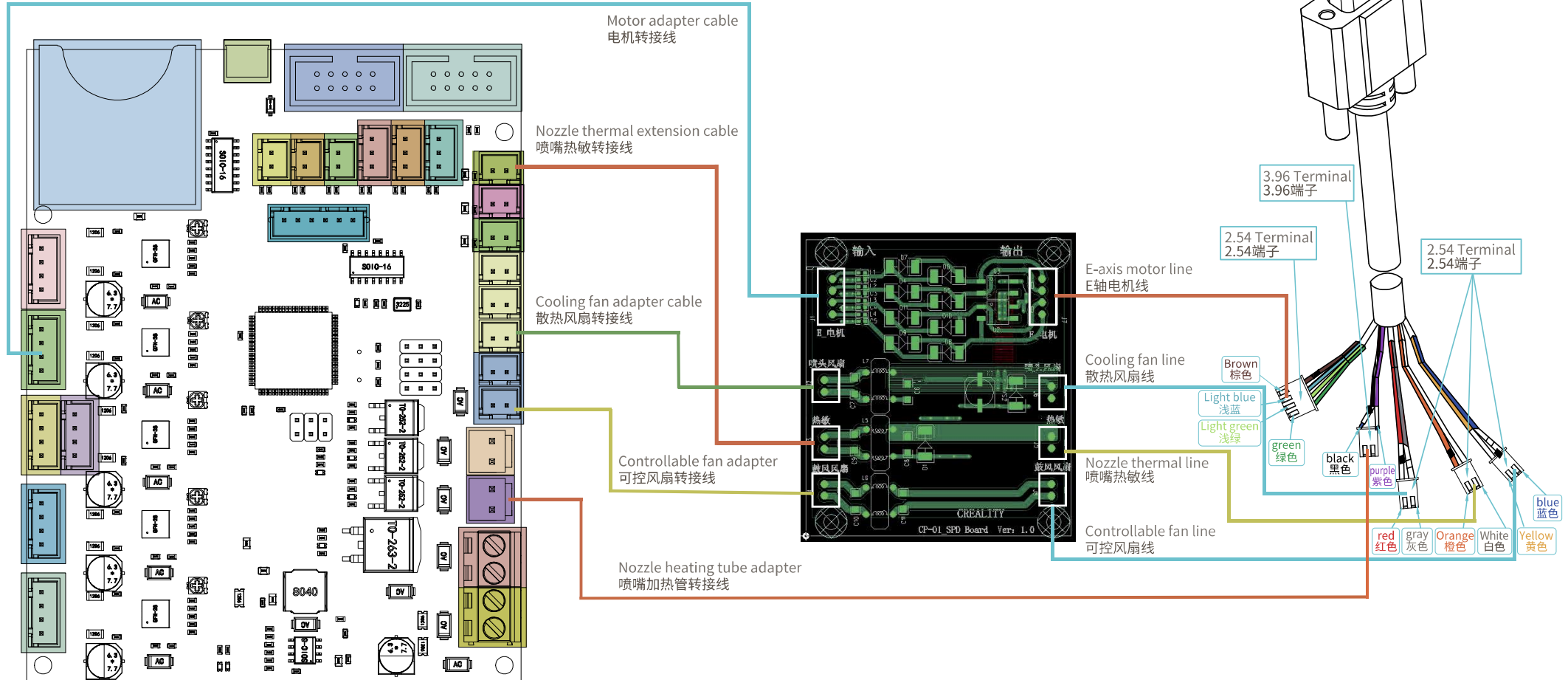

# Trouble-Shooting

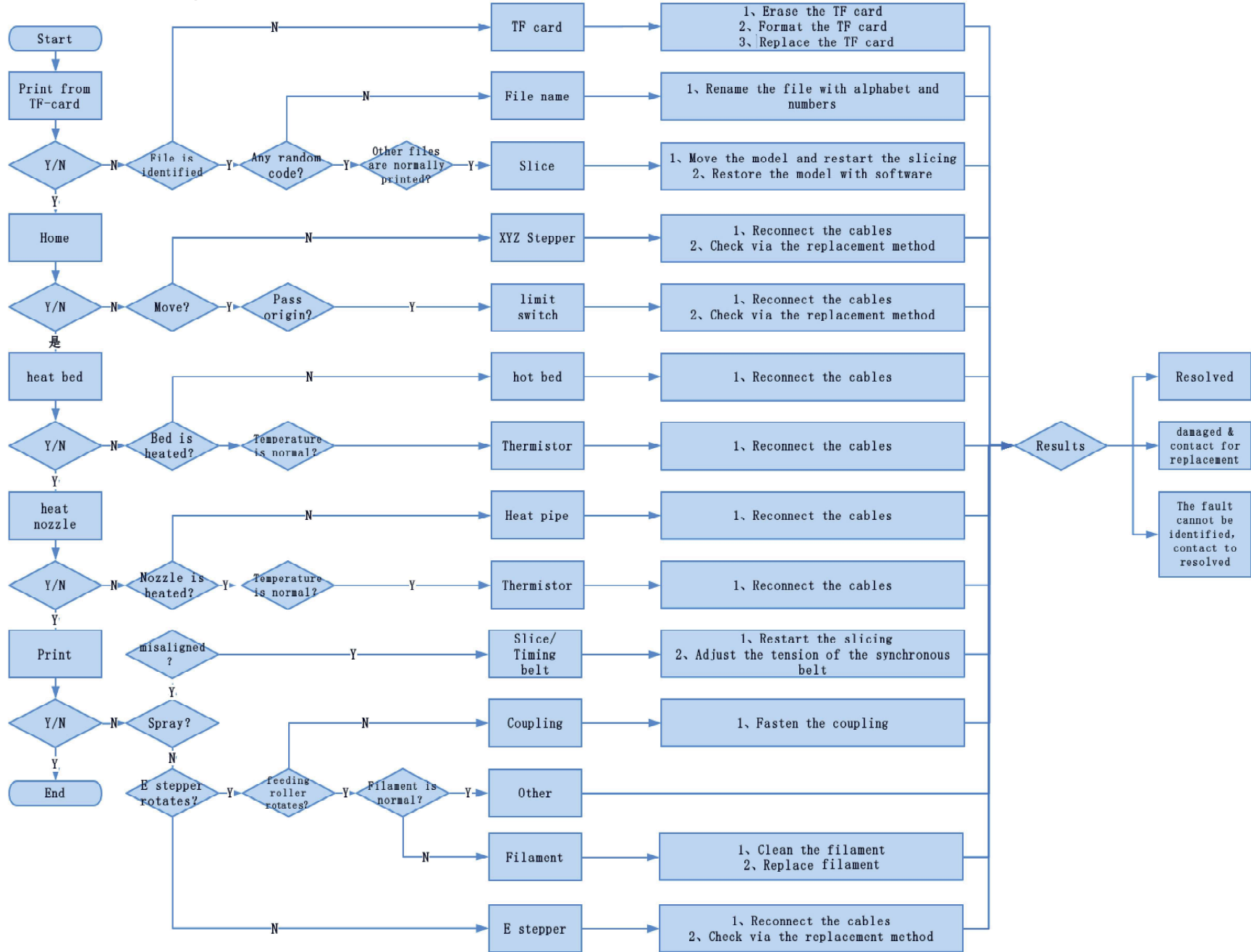

# 故障检修

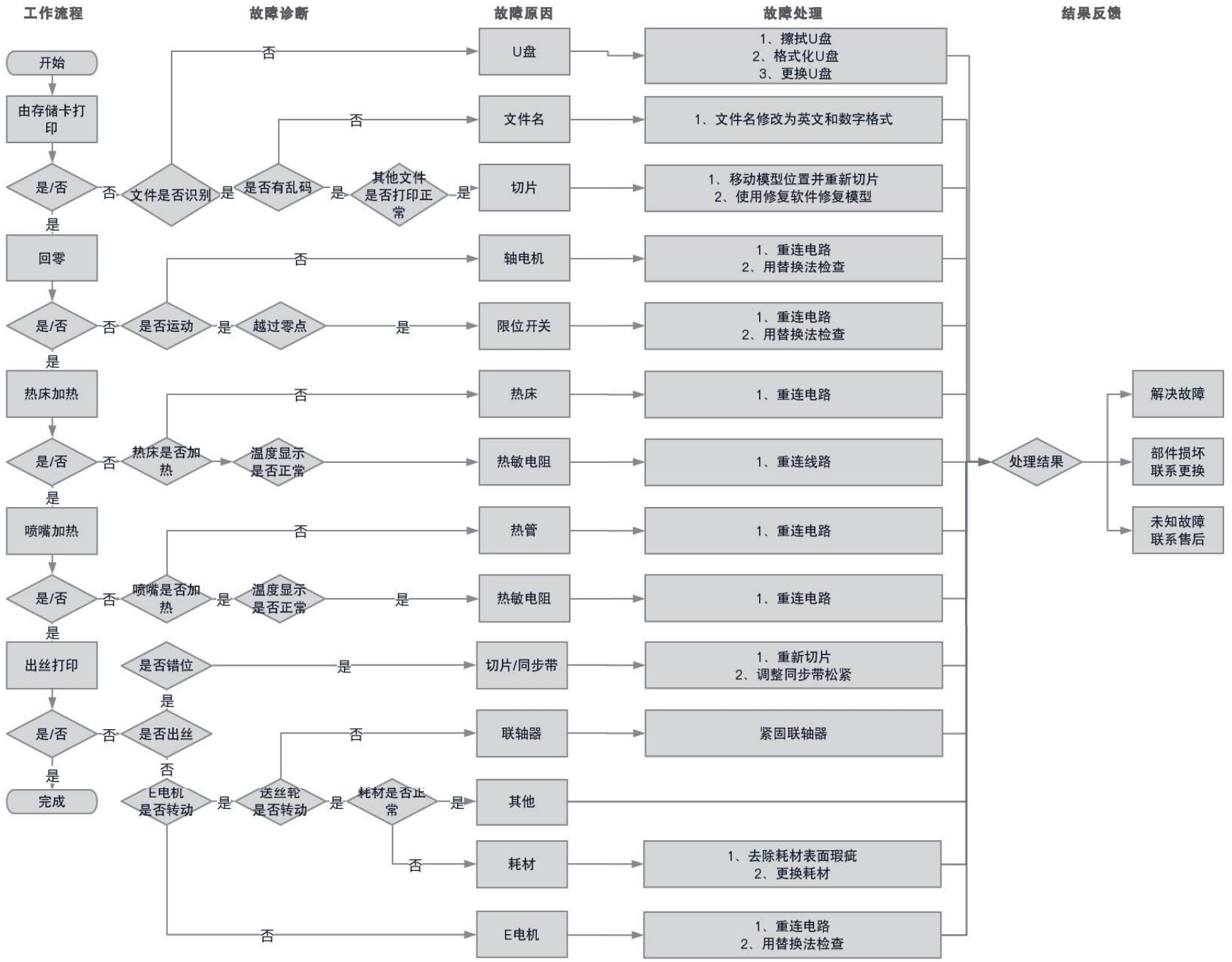

Due to the differences between different machine models, the physical objects and the final images can differ. The final explanation rights shall be reserved by Shenzhen Creality 3D Technology Co., Ltd.

因每款机型不同,实物与图可能有所差异, 请以实物为准, 最终解释归深圳市创想三维科技有限公司所有。



**SHENZHEN CREALITY 3D TECHNOLOGY CO.,LTD.**

11F & Room 1201,Block 3,JinChengYuan,Tongsheng Community,  
Dalang,Longhua District,Shenzhen,China,518109  
Official Website: [www.creality.com](http://www.creality.com)  
Tel: +86 755-8523 4565  
E-mail: [info@creality.com](mailto:info@creality.com) [cs@creality.com](mailto:cs@creality.com)



**深圳市创想三维科技有限公司**

深圳市龙华区大浪街道同胜社区金城工业园第三栋1201、11层  
公司网站: [www.cxsw3d.com](http://www.cxsw3d.com)  
服务热线: 400 6133 882  
0755-8523 4565

