

OWNER'S SERVICE MANUAL

G230RC/G260RC

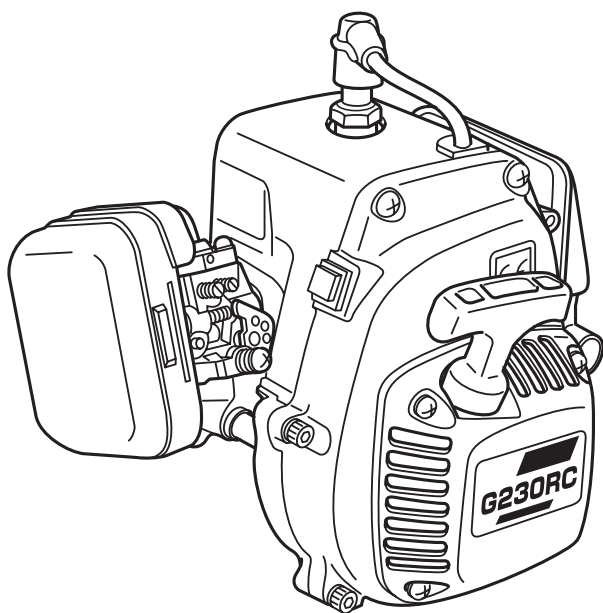

! WARNING !

- This engine is designed for the radio controlled car use. Zenoah assumes that no responsibility for this engine that is modified or used for any other applications. Purchaser has all responsibility against any laws and regulations existing in the country, Zenoah is exempt from such law and regulations.
- Read this OWNER'S SERVICE MANUAL before operating this engine.

! WARNING !

The engine exhaust from this product contains chemicals known to the State of California to cause cancer, birth defects or other reproductive harm.

! AVERTISSEMENT !

Les échappements du moteur de ce produit contiennent des produits chimiques connus par l'Etat de Californie comme étant responsables de cancers, d'anomalies congénitales et d'autres atteintes à l'appareil reproducteur.

! ADVERTENCIA !

Los gases de escape del motor de este producto contienen sustancias químicas conocidas por el Estado de California como causantes de cáncer, malformaciones en recién nacidos y otros problemas de reproducción.

1. Specifications

Engine Type	G230RC	G260RC
Overall Size (L x W x H)	167 x 204 x 195mm	
Weight	2.07kg	
Displacement	22.5cm ³	25.4cm ³
Clutch Engagement	6000rpm (STD Spring)	
Carburetor Type	WT-603B	
Spark Plug	NGK CMR7H	
Spark Plug Gap	0.65mm	
Rotating Direction	Counter-Clockwise (View From PTO)	

2. Fuel

- Mix high-octane (over 95) gasoline and high grade 2 cycle oil (JASO FC Grade oil or ISO EGC grade) in the ratio of 25 : 1.



⚠ WARNING

- 1) Never use any alcohol fuel or alcohol added fuel, or the rubber parts in the carburetor and engine will be damaged.
- 2) Gasoline is very flammable. Avoid smoking, bringing any fires near fuel.
- 3) To prevent all possible problem on fueling system, make sure to use the fuel filter and fuel pipe packed as accessories.

3. Engine Starting

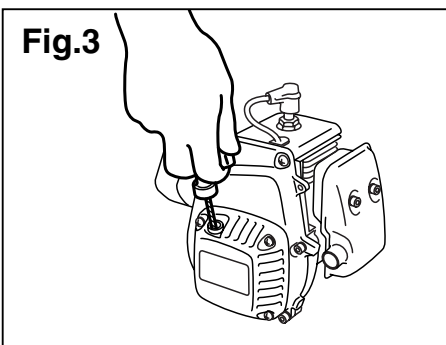
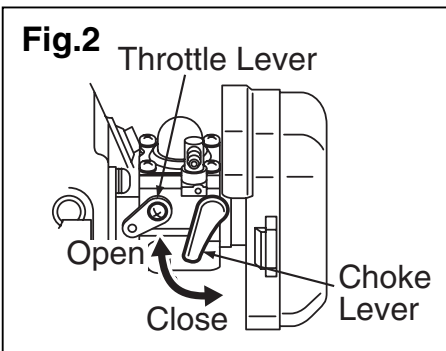
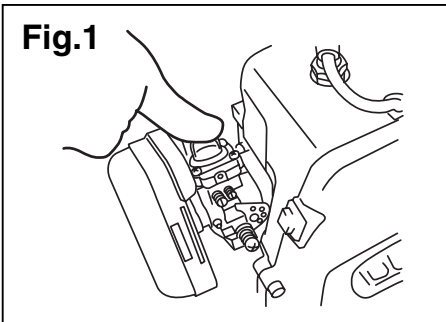

- Push the primer pump several times until overflow fuel flows out. (Fig.1)
- Close the choke lever(Fig.2), and move the throttle lever 1/4~1/3 open position.
- Pull the starter(knob) quickly until first firing noise. (Fig.3)
- Open the choke(Fig.2), throttle idle~1/4 open
- Pull the starter quickly
- Operate engine for a few minutes for the warming up.

! IMPORTANT

- In case of engine warm condition, choking may not be necessary.
- Over choking may cause starting difficulty due to wet spark plug.
In this case change spark plug or dry it, and remove fuel rest in the cylinder by pulling starter.

4. Operation

- This engine is already tuned up to get high power and high speed, and needs correct maintenance to keep such high performance.
- The details for operation may be described in the separate owners manual to be issued by car manufacturer.
- Be sure to have the engine cool down for 30 seconds at idle speed after full throttle running.

5. Maintenance

1) MAINTENANCE CHART

Items	Action	Before Use	Every 25 hours	Every 100 hours	Note
Leakage, Damage/Crack	Check	✓			
Idling Speed	Check/Adjust	✓	✓	✓	
Air-cleaner	Check/Cleaning	✓	✓		Replace if necessary
Spark Plug(gap)	Check/Adjust		✓	✓	↑
Cylinder(barrel)	Check/Cleaning		✓	✓	↑
Piston, Ring	Check/Cleaning		✓	✓	↑
Muffler & Bolt	Check/Cleaning	✓	✓	✓	↑
Bearings	Check/Cleaning		✓	✓	↑
Crank Shaft	Check/Alignment			✓	↑

2) SPECIFICATIONS AND TECHNICAL DATA

Items	Unit	G230RC	G260RC	Remarks
Bore x Stroke	mm	32 x 28	34 x 28	
Displacement	cm ³	22.5	25.4	
Effective Compression Ratio		9.2	8.8	
Carburetor	Type	Walbro WT	←	
	Venture(mm)	ø12.7	←	
Starting		Recoil Starter	←	
Ignition	Type	TCI	←	
	Timing	BTC 30°/8000rpm	←	
Spark Plug	Standard	CMR7H	←	NGK
	Option(For Race)	CR8HIX with Terminal Nut	←	↑
	Option(Hot Type)	CMR6H	←	↑
Clutch Engagement Speed	rpm	6000	←	
No load max Speed	rpm	19500	←	
Idling Speed	rpm	4000	←	
Max. Net Power	kW/rpm	1.79/12000	1.82/12500	Without Air Cleaner and Muffler
Max. Net Torque	N.m/rpm	1.55/9000	1.60/9000	↑
Fuel Consumption	g/kW·h	750 (550)	765 (565)	↑
Carburetor Standard setting	H	1 3/4 ± 1/4	←	
	L	1 1/2 ± 1/4	←	

5. Maintenance

3) MAINTENANCE SPECIFICATIONS

	Items	G230RC		G260RC		Measuring Device	Remarks
		Standard	Limit	Standard	Limit		
Cylinder	Bore (mm)	ø32	Plating damaged	ø34	Plating damaged	Eye Checking	
Piston	Diameter (mm)	ø31.97	ø31.87	ø33.97	ø33.87	Micro Meter	At the skirt end and the right angle to the piston pin.
	Piston Ring Groove width (mm)	0.81	0.91	1.01	1.11	Thickness Gauge	
	Piston Pin Hole (mm)	ø8.01	ø8.05	ø8.01	ø8.05	Cylinder Gauge	
	Clearance between Piston and Cylinder (mm)	0.03~0.06	0.15	0.03~0.06	0.15	Micro Meter Cylinder Gauge	
	Clearance between Groove and Piston Ring (mm)	0.02~0.04	0.1	0.02~0.04	0.1	Thickness Gauge	
Piston Ring	End Gap (mm)	0.05~0.25	0.5	0.05~0.25	0.5	Thickness Gauge	When inserted in a new cylinder.
	Width (mm)	0.78	0.73	0.98	0.93	Micro Meter	
	Piston Pin Diameter (mm)	ø8	ø7.98	ø8	ø7.98	Micro Meter	
	Connecting Rod Small end (mm)	ø11	ø11.05	ø11	ø11.05	Cylinder Gauge	
Crankshaft Dia. at Main Bearing (mm)		ø12	ø11.98	ø12	ø11.98	Micro Meter	
	Eccentricity (mm)	—	0.07	—	0.07	Dial Gauge	
	Axial Play (mm)	—	0.5	—	0.5	Thickness Gauge	
	Main Bearing	—	Gritty or Feels Flat Spot	—	Gritty or Feels Flat Spot	—	

4) CARBURETOR

Items	Standard	Limit	Measuring Device	Remarks
Metering Lever set (mm)	1.65	± 0.16	Vanier	
Inlet Valve Opening Pressure (kg/cm ²)	1.3~2.3		Leak Tester	
Inlet Valve Closing Pressure (kg/cm ²)	0.7~1.7		Leak Tester	

5. Maintenance

5) IGNITION SYSTEM



Items		Standard	Limit	Measuring Device	Remarks
Spark Plug Air Gap (mm)		0.6~0.7	0.7	Thickness Gauge	
Ignition Coil/Flywheel Air Gap (mm)		0.3	0.4	Thickness Gauge	
Coil Resistance (Ω)	Primary	0.7	—	Volt Meter	Reading between primary terminal and iron core.
	Secondary	6100	—	Volt Meter	Reading between sparking cord end and iron core.

6) TIGHTENING TORQUE

Items	Screw Size	Standard (kg-cm)	Limit (kg-cm)	Remarks
Carburetor	M5 (P=0.8)	35	30~40	
Insulator	M5 (P=0.8)	35	30~40	with Locktight glue
Clutch	M6 (P=1.0)	65	50~80	
Rotor	M8 (P=1.0)	130	100~150	
Cylinder	M5 (P=0.8)	70	60~80	
Crankcase	M5 (P=0.8)	65	50~80	
Spark Plug	M10 (P=1.0)	110	100~120	
Muffler	M5 (P=0.8)	90	70~100	
Fan Cover	M5 (P=0.8)	35	30~40	
Ignition Coil	M4 (P=0.7)	33	25~40	
Starter Case	M4 (P=0.7)	13	10~15	
Tapping Screw	TP 4.3	25	20~30	

6. Special Tools

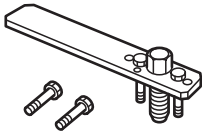
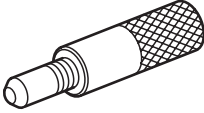
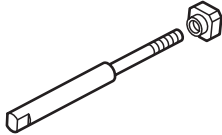
7) SPECIAL TOOLS

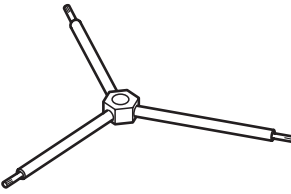
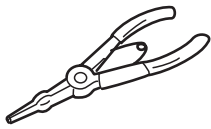
	Part Name	Part No.	External Appearance	Usage
1	Puller Assy	2890-96100		To remove rotor.
2	Piston Stopper	4810-96220		To hold crankshaft when disassembling/assembling clutch and rotor.
3	Rod Assy	1101-96220		To remove/install piston pin.
4	Air Gap Gauge	3330-97310		To set ignition coil.
5	Hex Wrench	3304-97611		For socket screw of Hex. 3mm, 4mm and 5mm.
6	Snap Ring Pliers	5500-96110		To remove snap ring.

7. Service Guide

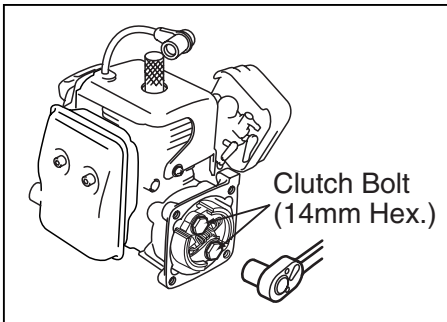

1) REMOVING CLUTCH SHOE

1. Remove the housing and plug cap.
2. Remove the spark plug and fit the stopper(4810-96220) into the plug hole.
3. Remove clutch bolts(14mm Hex.).

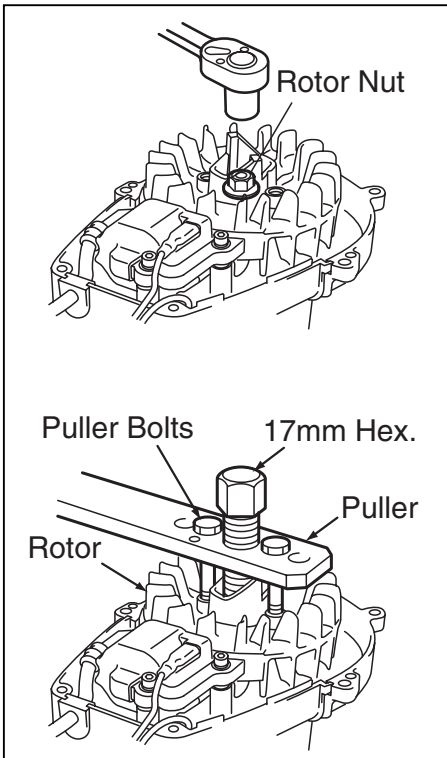

2) REMOVING ROTOR (FAN)

4. Remove the rotor nut(12mm Hex.).
5. Remove the rotor using the puller assy (2890-96100). Apply 8mm puller bolts.

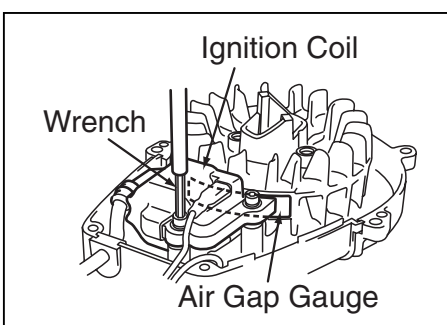

3) ASSEMBLING ROTOR

Insert the gauge(3330-97310) in between the rotor magnet metal and the coil.Tighten screws while pressing the coil against the rotor.

Air Gap 0.3 ~ 0.4mm

7. Service Guide

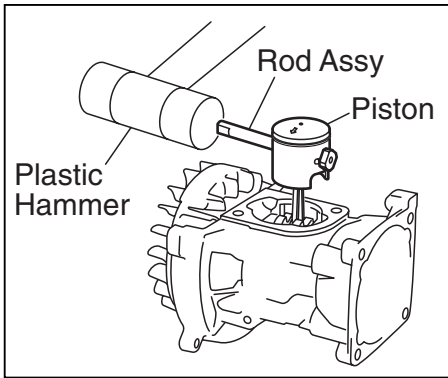

4) REMOVING PISTON PIN

1. Remove snap rings from both sides of the piston pin.
2. Engage the rod assy(1101-96220) to the piston pin and gently tap with a plastic hammer to push out the pin while holding piston firmly.

NOTE

Hard hammering may damage the big end of the connecting rod.

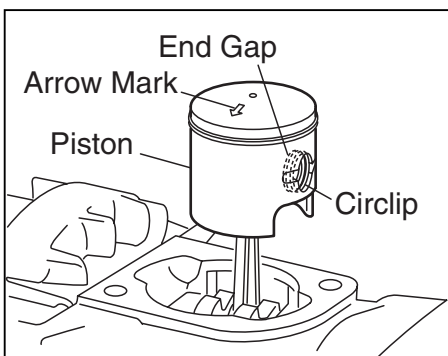

5) INSTALLING PISTON

1. Make sure to point the arrow mark on the piston to the exhaust side.
2. Fit the circlip in the groove so as to face the end gap below.

NOTE

Deformed circlip may come off during engine operation and damage the engine.

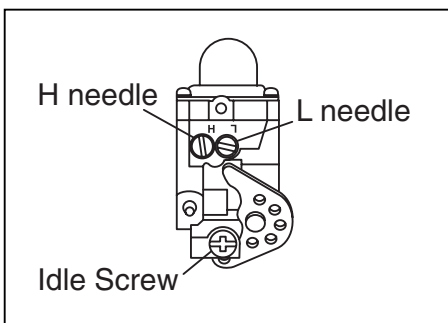

6) CARBURETOR ADJUSTMENT

The carburetor comes with a standard setting, it is for optimum performance under the barometric pressure and climatic conditions at factory, so it may be re-adjusted according to load applied.

Idle rpm : 4000 ± 300 rpm (STD Spring)

H needle : 1 3/8 ± 1/4

L needle : 1 1/4 ± 1/4

9. Trouble Shooting

1) ENGINE DOES NOT START

Description	Cause	Countermeasure
No spark in the spark plug		
Spark Plug	1. Wet spark plug electrodes	Make them dry
	2. Carbon deposited on the electrodes	Cleaning
	3. Insulation failure by insulator damage	Exchange
	4. Inproper spark gap	Adjust to 0.6~0.7mm
	5. Burn out of electrodes	Exchange
Magneto	1. Ignition coil inside failure	Exchange
	2. Damaged cable sheath or disconnected cable	Exchange or repair
Switch	1. Switch is OFF	ON the switch
	2. Switch failure	Exchange
	3. Primary wiring earthed	Repair
Sparks appear in the spark plug		
Compression & fueling is normal	1. Over sucking of fuel	Drain excess fuel
	2. Too rich fuel	Adjust carburetor
	3. Overflow	Carburetor adjust or exchange
	4. Clogging of air cleaner	Wash with mixed gasoline
	5. Faulty fuel	Change with proper fuel
Fueling normal but poor compression	1. Worn out cylinder, piston, or piston ring	Exchange
	2. Gas leakage from cylinder and crank case gasket	Apply liquid gasket and reassemble.
No fuel supply	1. Choked breather air hole	Cleaning
	2. Clogged carburetor	Cleaning
	3. Clogged fuel filter	Exchange fuel filter

2) LACK OF POWER OR UNSTABLE RUNNING

Description	Cause	Countermeasure
Compression is normal and no misfire	1. Air penetration from fuel pipe joints, etc	Secure connection
	2. Air penetration from intake tube joint or carburetor joint	Change gasket or tightening screws
	3. Water in fuel	Change with good fuel
	4. Piston start to seizure	Replace piston (and cylinder)
	5. Muffler choked with carbon	Cleaning
Overheating	1. Fuel too lean	Adjust carburetor
	2. Clogging of cylinder fin with dust	Cleaning
	3. Poor fuel quality	Exchange with proper fuel
	4. Carbon deposited in the combustion chamber	Cleaning
	5. Spark plug electrode red hot	Thoroughly clean, adjust spark gap [0.6~0.7(0.023~0.028in)]
Others	1. Dirty air cleaner	Wash with mixed gasoline
	2. Over loading	Reduce load

10. Parts list (G230RC)

G230RC

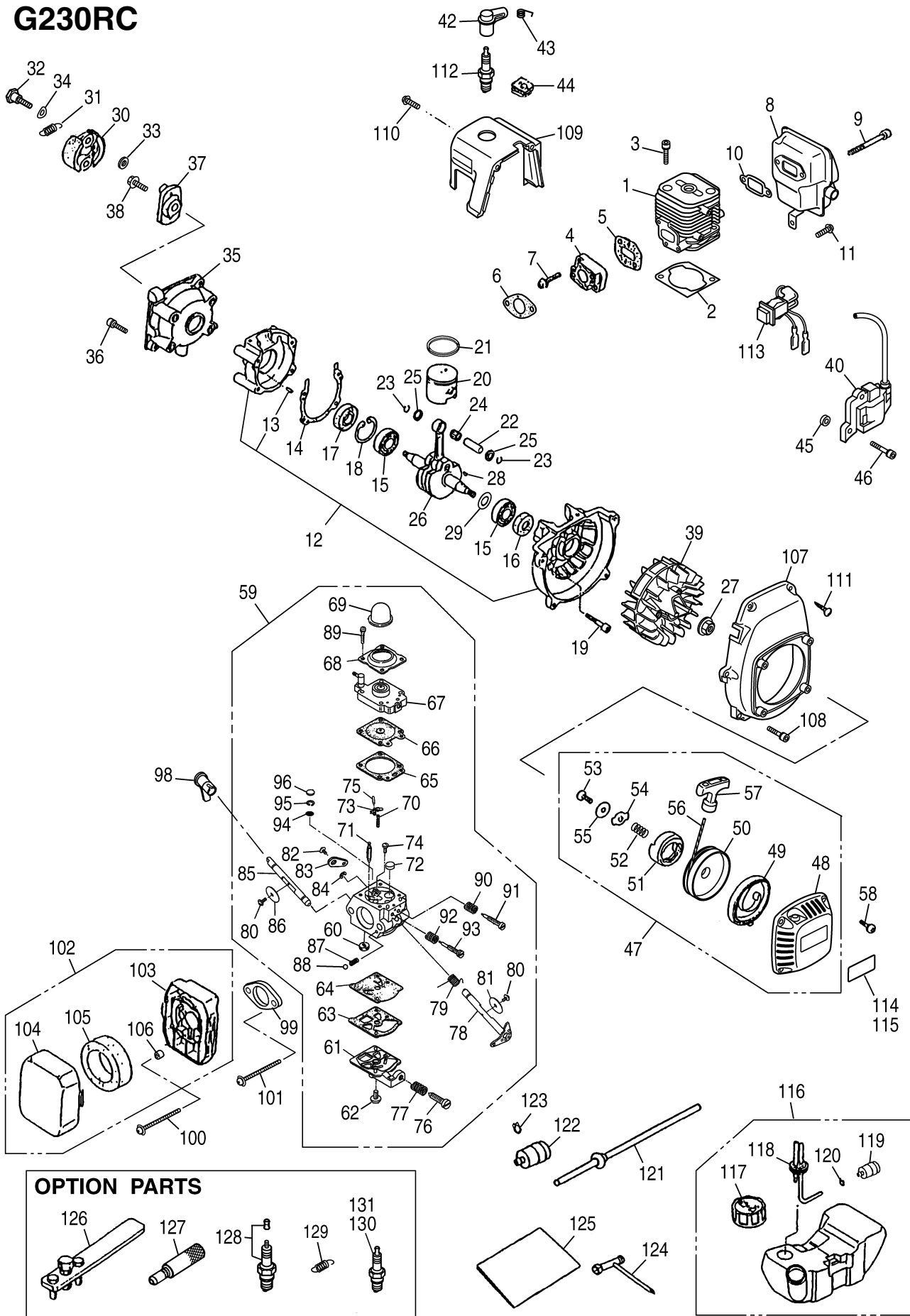

10. Parts list (G230RC)

Key#	Part Number	Description	Q'ty	Model Name & Cord				Remarks
				GR23101 G230RC	GR23102 G230RC1	GR23103 G230RC2	GR23104 G230RC3	
1	T2070-12111	CYLINDER	1	●	●	●	●	
2	848-ER0-97Z0	GASKET	1	●	●	●	●	
3	01252-30522	BOLT	2	●	●	●	●	M5x22L
4	1148-13162	INSULATOR	1	●	●	●	●	
5	T2075-13150	GASKET, INSU	1	●	●	●	●	
6	T2075-14120	GASKET, CARB	1	●	●	●	●	
7	3310-12281	SCREW	2	●	●	●	●	M5x20L
8	T2070-15110	MUFFLER	1	●	●	—	—	
9	01252-30550	BOLT	2	●	●	—	—	M5x50L
10	1140-13141	GASKET, MUFFLER	1	●	●	●	●	
11	1850-32160	SCREW	1	●	●	—	—	M4x12L
12	T2070-21102	CRANKCASE-C	1	●	●	●	●	
13	2629-21130	• PIN	3	●	●	●	●	
14	5500-21141	GASKET, CASE	1	●	●	●	●	
15	1155-21240	BEARING	2	●	●	●	●	
16	2169-21210	SEAL	1	●	●	●	●	
17	1850-21220	SEAL	1	●	●	●	●	
18	04065-02812	RING	1	●	●	●	●	
19	01252-30530	BOLT	4	●	●	●	●	M5x30L
20	T2071-41110	PISTON	1	●	●	●	●	
21	T2071-41210	RING	1	●	●	●	●	
22	1101-41310	PIN	1	●	●	●	●	
23	1260-41320	RING	2	●	●	●	●	
24	5500-41410	BEARING	1	●	●	●	●	
25	1101-41340	WASHER	2	●	●	●	●	
26	T2070-42001	CRANKSHAFT-C	1	●	●	●	●	
27	1650-43230	NUT	1	●	●	●	●	M8x1.0
28	1000-43240	KEY	1	●	●	●	●	
29	1140-43250	SIM	1	●	●	●	●	
30	1140-51111	SHOE	2	●	●	—	—	
31	T2070-51220	SPRING	1	●	●	●	—	(6000rpm IN)
32	1140-51250	SCREW	2	●	●	●	—	M6x22L
33	1140-51230	WASHER	2	●	●	●	—	
34	1140-51242	WASHER	2	●	●	●	—	
35	1140-21162	CASE, CLUTCH	1	●	●	●	—	
36	3350-15250	BOLT	4	●	●	●	—	M5x16L
37	1140-55310	PLATE	1	●	●	●	—	
38	0224-30614	BOLT	1	●	●	●	—	M6x14L
39	T2070-71110	ROTOR	1	●	●	●	●	
40	T2070-71200	COIL-A	1	●	●	●	●	
42	T2075-72210	CAP	1	●	●	●	●	
43	1400-72121	SPRING	1	●	●	●	●	
44	5500-72130	GROMMET	1	●	●	●	●	
45	1260-71261	SPACER	2	●	●	●	●	
46	3350-14150	BOLT	2	●	●	●	●	M4x20L
47	T2070-75101	RECOIL-A	1	●	●	●	●	
48	T2070-75110	• CASE	1	●	●	●	●	
49	5990-75120	• SPRING, SPIRAL	1	●	●	●	●	
50	5990-75131	• REEL	1	●	●	●	●	
51	5990-75141	• RATCHET	1	●	●	●	●	
52	5990-75151	• SPRING, BREAK	1	●	●	●	●	
53	5990-75270	• SCREW	1	●	●	●	●	
54	5990-75160	• RETAINER	1	●	●	●	●	
55	5990-75170	• WASHER	1	●	●	●	●	
56	1861-75180	• ROPE	1	●	●	●	●	
57	1490-75181	• KNOB	1	●	●	●	●	
58	0263-90416	SCREW	4	●	●	●	●	M4x16L
59	T2070-81002	CARBURETOR-A	1	●	●	●	●	WT-603B
60	3306-81380	• SCREEN	1	●	●	●	●	
61	3080-81120	• COVER	1	●	●	●	●	
62	3310-81130	• SCREW	1	●	●	●	●	
63	3304-81140	• GASKET	1	●	●	●	●	
64	1172-81150	• DIAPHRAGM	1	●	●	●	●	
65	1751-81470	• GASKET	1	●	●	●	●	
66	3310-81260	• DIAPHRAGM	1	●	●	●	●	

10. Parts list (G230RC)

G230RC

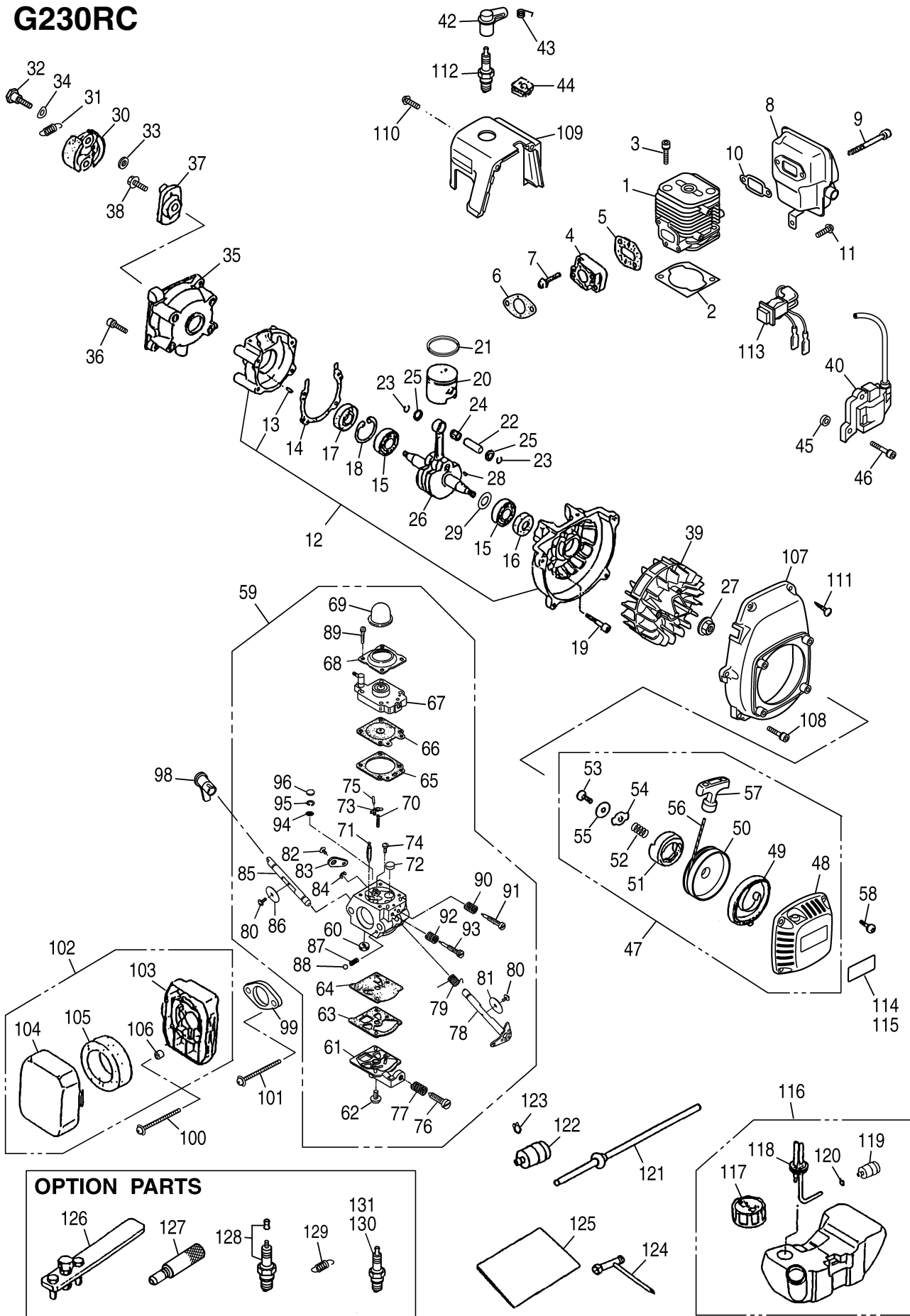

10. Parts list (G230RC)

Key#	Part Number	Description	Q'ty	Model Name & Cord				Remarks
				GR23101 G230RC	GR23102 G230RC1	GR23103 G230RC2	GR23104 G230RC3	
67	T2070-81210	• BODY-A	1	●	●	●	●	
68	1751-81520	• COVER	1	●	●	●	●	
69	1751-81510	• PUMP	1	●	●	●	●	
70	2867-81270	• SPRING	1	●	●	●	●	
71	3356-81310	• VALVE inlet	1	●	●	●	●	
72	1480-81420	• PLUG welch	1	●	●	●	●	
73	3310-81230	• LEVER	1	●	●	●	●	
74	3310-81240	• SCREW	1	●	●	●	●	
75	3310-81250	• PIN	1	●	●	●	●	
76	2630-81330	• SCREW	1	●	●	●	●	
77	3350-81380	• SPRING	1	●	●	●	●	
78	T2070-81370	• SHAFT throttle	1	●	●	●	●	
79	2670-81410	• SPRING	1	●	●	●	●	
80	2880-81470	• SCREW	2	●	●	●	●	
81	3310-81340	• VALVE throttle	1	●	●	●	●	
82	3310-81360	• SCREW	1	●	●	●	●	
83	1790-81440	• LEVER throttle	1	●	●	●	●	
84	1148-81390	• RING	1	●	●	●	●	
85	T2070-81460	• SHAFT choke	1	●	●	●	●	
86	2670-81450	• VALVE choke	1	●	●	●	●	
87	3350-81350	• SPRING	1	●	●	●	●	
88	3350-81220	• BALL	1	●	●	●	●	
89	1148-81530	• SCREW	4	●	●	●	●	
90	1491-81160	• SPRING	1	●	●	●	●	
91	T2070-81170	• NEEDLE low speed	1	●	●	●	●	
92	3080-81320	• SPRING	1	●	●	●	●	
93	T2070-81331	• NEEDLE high speed	1	●	●	●	●	
94	3304-81450	• SCREEN	1	●	●	●	●	
95	3304-81441	• RING	1	●	●	●	●	
96	3360-81440	• PLUG	1	●	●	●	●	
98	T2070-82410	LEVER	1	●	●	●	●	
99	T2070-82510	SPACER	1	●	●	●	●	
100	0263-90560	SCREW	2	●	●	—	—	M5x60L
101	0263-90550	SCREW	2	—	—	—	●	M5x50L
102	T2070-82000	CLEANER-A	1	●	●	●	●	
103	5731-82011	• HOUSING	1	●	●	—	—	
104	5730-82040	• COVER	1	●	●	—	—	
105	1571-82020	• FILTER	1	●	●	—	—	
106	5730-82060	• SLEEVE	2	●	●	—	—	
107	T2070-31111	COVER, FAN	1	●	●	●	●	
108	3310-12281	BOLT	4	●	●	●	●	M5x20L
109	T2070-32100	COVER-A	1	●	●	●	●	
110	1850-32160	SCREW	1	●	●	●	●	M4x12L
111	1900-31410	SCREW	2	●	●	●	●	TP4.5x18L
112	3699-91867	SPARKPLUG	1	●	●	●	●	NGK CMR7H
113	T2070-72200	SWITCH-A	1	●	●	●	●	
114	T2070-75410	LABEL, RECOIL	1	●	—	●	●	
115	T2071-75410	LABEL, RECOIL	1	—	●	—	—	
116	1726-85005	TANK-A	1	●	●	●	●	OP
117	5601-85201	• CAP-A	1	●	●	●	●	OP
118	1726-85601	• PIPE COMP	1	●	●	●	●	OP
119	5500-85400	• FILTER	1	●	●	●	●	OP
120	1260-85460	• CLIP	1	●	●	●	●	OP
121	1799-85400	PIPE COMP	1	●	—	●	●	
122	5500-85400	FILTER	1	●	—	●	●	
123	1260-85460	CLIP	1	●	—	●	●	
124	T3039-91310	SOCKET	1	●	●	●	●	
125	T2070-93112	MANUAL	1	●	●	●	●	
126	2890-96100	PULLER-A	1	●	●	●	●	OP
127	4810-96220	STOPPER	1	●	●	●	●	OP
128	848-ETZ-71T0	SPARKPLUG	1	●	●	●	●	OP (NGK CR8HIX with Terminal Nut)
129	1764-51220	SPRING	1	●	●	●	—	OP (5000rpm IN)
130	3699-91975	SPARKPLUG	1	●	●	●	●	OP (NGK CMR6H)
131	3699-91809	SPARKPLUG	1	●	●	●	●	OP (CHAMPION RZ7C)

10. Parts list (G260RC)

G260RC

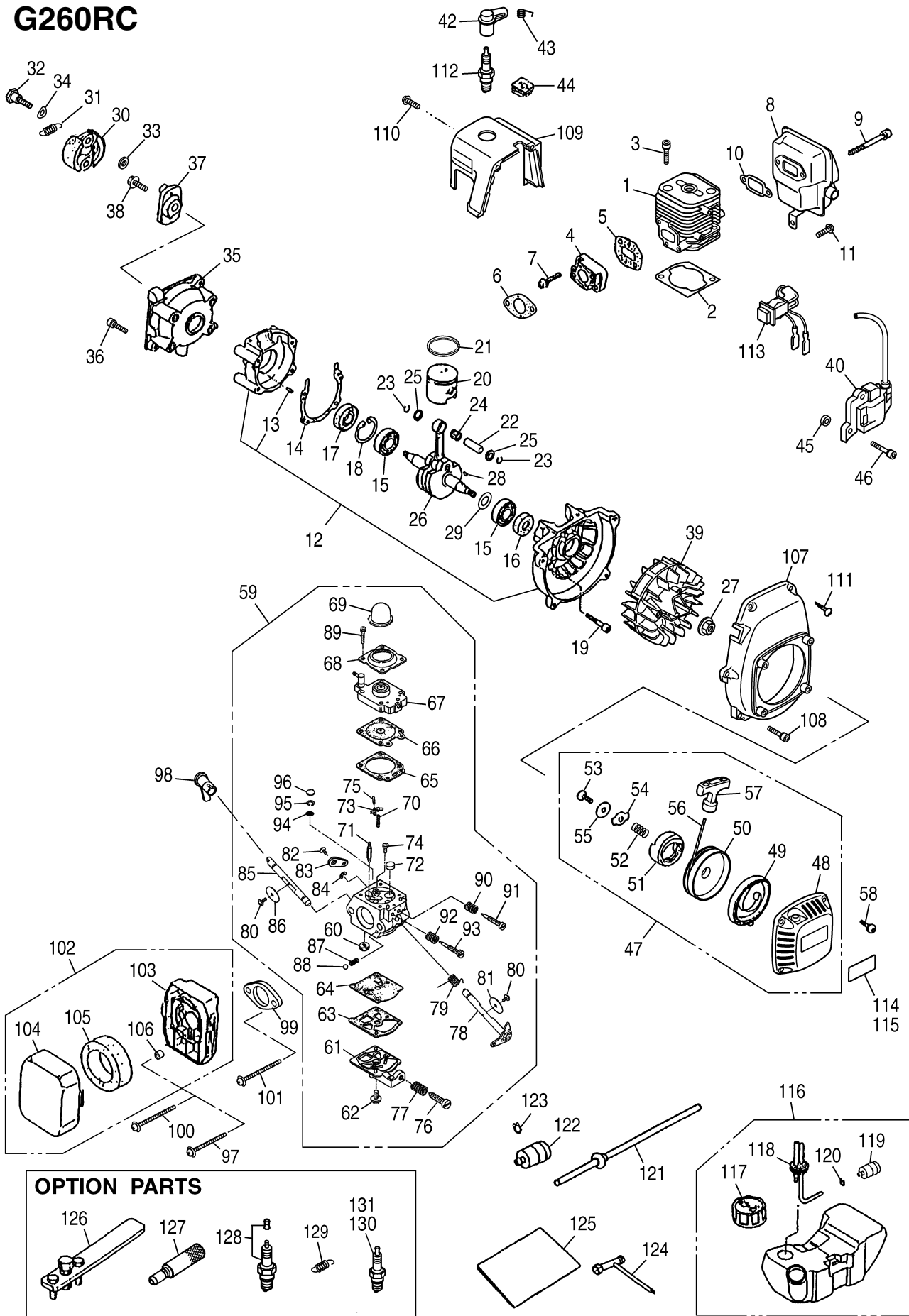

10. Parts list (G260RC)

Key#	Part Number	Description	Q'ty	Model Name & Cord				Remarks
				GR26101 G260RC	GR26102 G260RC1	GR26103 G260RC2	GR26104 G260RC3	
1	T2700-12110	CYLINDER	1	●	●	●	●	
2	848-ER0-97Z0	GASKET	1	●	●	●	●	
3	01252-30522	BOLT	2	●	●	●	●	M5x22L
4	1148-13162	INSULATOR	1	●	●	●	●	
5	T2075-13150	GASKET, INSU	1	●	●	●	●	
6	T2075-14120	GASKET, CARB	1	●	●	●	●	
7	3310-12281	SCREW	2	●	●	●	●	M5x20L
8	T2070-15110	MUFFLER	1	●	●	—	—	
9	01252-30550	BOLT	2	●	●	—	—	M5x50L
10	1140-13141	GASKET, MUFFLER	1	●	●	●	●	
11	1850-32160	SCREW	1	●	●	—	—	M4x12L
12	T2070-21102	CRANKCASE-C	1	●	●	●	●	
13	2629-21130	• PIN	3	●	●	●	●	
14	5500-21141	GASKET, CASE	1	●	●	●	●	
15	1155-21240	BEARING	2	●	●	●	●	
16	2169-21210	SEAL	1	●	●	●	●	
17	1850-21220	SEAL	1	●	●	●	●	
18	04065-02812	RING	1	●	●	●	●	
19	01252-30530	BOLT	4	●	●	●	●	M5x30L
20	T2088-41110	PISTON	1	●	●	●	●	
21	T2088-41210	RING	1	●	●	●	●	
22	1600-41310	PIN	1	●	●	●	●	
23	1260-41320	RING	2	●	●	●	●	
24	5500-41410	BEARING	1	●	●	●	●	
25	1101-41340	WASHER	2	●	●	●	●	
26	T2070-42001	CRANKSHAFT-C	1	●	●	●	●	
27	1650-43230	NUT	1	●	●	●	●	M8x1.0
28	1000-43240	KEY	1	●	●	●	●	
29	1140-43250	SIM	1	●	●	●	●	
30	1140-51111	SHOE	2	●	●	●	—	
31	T2070-51220	SPRING	1	●	●	●	—	(6000rpm IN)
32	1140-51250	SCREW	2	●	●	●	—	M6x22L
33	1140-51230	WASHER	2	●	●	●	—	
34	1140-51242	WASHER	2	●	●	●	—	
35	1140-21162	CASE, CLUTCH	1	●	●	●	—	
36	3350-15250	BOLT	4	●	●	●	—	M5x16L
37	1140-55310	PLATE	1	●	●	●	—	
38	0224-30614	BOLT	1	●	●	●	—	M6x14L
39	T2070-71110	ROTOR	1	●	●	●	●	
40	T2070-71200	COIL-A	1	●	●	●	●	
42	T2075-72210	CAP	1	●	●	●	●	
43	1400-72121	SPRING	1	●	●	●	●	
44	5500-72130	GROMMET	1	●	●	●	●	
45	1260-71261	SPACER	2	●	●	●	●	
46	3350-14150	BOLT	2	●	●	●	●	M4x20L
47	T2070-75101	RECOIL-A	1	●	●	●	●	
48	T2070-75110	• CASE	1	●	●	●	●	
49	5990-75120	• SPRING, SPIRAL	1	●	●	●	●	
50	5990-75131	• REEL	1	●	●	●	●	
51	5990-75141	• RATCHET	1	●	●	●	●	
52	5990-75151	• SPRING, BREAK	1	●	●	●	●	
53	5990-75270	• SCREW	1	●	●	●	●	
54	5990-75160	• RETAINER	1	●	●	●	●	
55	5990-75170	• WASHER	1	●	●	●	●	
56	1861-75180	• ROPE	1	●	●	●	●	
57	1490-75181	• KNOB	1	●	●	●	●	
58	0263-90416	SCREW	4	●	●	●	●	M4x16L
59	T2070-81002	CARBURETOR-A	1	●	●	●	●	WT-603B
60	3306-81380	• SCREEN	1	●	●	●	●	
61	3080-81120	• COVER	1	●	●	●	●	
62	3310-81130	• SCREW	1	●	●	●	●	
63	3304-81140	• GASKET	1	●	●	●	●	
64	1172-81150	• DIAPHRAGM	1	●	●	●	●	
65	1751-81470	• GASKET	1	●	●	●	●	
66	3310-81260	• DIAPHRAGM	1	●	●	●	●	

10. Parts list (G260RC)

G260RC

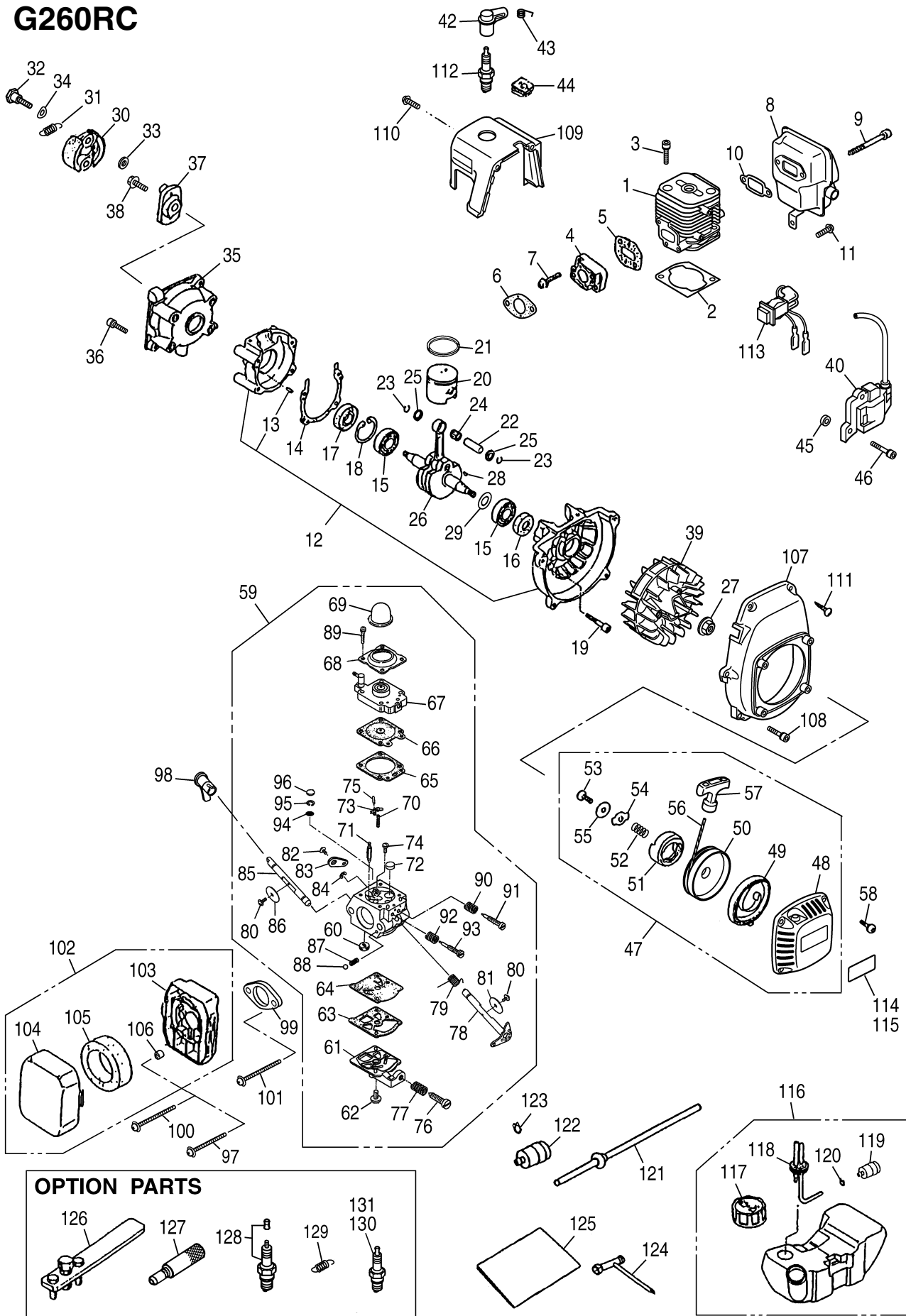

10. Parts list (G260RC)

Key#	Part Number	Description	Q'ty	Model Name & Cord				Remarks
				GR26101 G260RC	GR26102 G260RC1	GR26103 G260RC2	GR26104 G260RC3	
67	T2070-81210	• BODY-A	1	●	●	●	●	
68	1751-81520	• COVER	1	●	●	●	●	
69	1751-81510	• PUMP	1	●	●	●	●	
70	2867-81270	• SPRING	1	●	●	●	●	
71	3356-81310	• VALVE inlet	1	●	●	●	●	
72	1480-81420	• PLUG welch	1	●	●	●	●	
73	3310-81230	• LEVER	1	●	●	●	●	
74	3310-81240	• SCREW	1	●	●	●	●	
75	3310-81250	• PIN	1	●	●	●	●	
76	2630-81330	• SCREW	1	●	●	●	●	
77	3350-81380	• SPRING	1	●	●	●	●	
78	T2070-81370	• SHAFT throttle	1	●	●	●	●	
79	2670-81410	• SPRING	1	●	●	●	●	
80	2880-81470	• SCREW	2	●	●	●	●	
81	3310-81340	• VALVE throttle	1	●	●	●	●	
82	3310-81360	• SCREW	1	●	●	●	●	
83	1790-81440	• LEVER throttle	1	●	●	●	●	
84	1148-81390	• RING	1	●	●	●	●	
85	T2070-81460	• SHAFT choke	1	●	●	●	●	
86	2670-81450	• VALVE choke	1	●	●	●	●	
87	3350-81350	• SPRING	1	●	●	●	●	
88	3350-81220	• BALL	1	●	●	●	●	
89	1148-81530	• SCREW	4	●	●	●	●	
90	1491-81160	• SPRING	1	●	●	●	●	
91	T2070-81170	• NEEDLE low speed	1	●	●	●	●	
92	3080-81320	• SPRING	1	●	●	●	●	
93	T2070-81331	• NEEDLE high speed	1	●	●	●	●	
94	3304-81450	• SCREEN	1	●	●	●	●	
95	3304-81441	• RING	1	●	●	●	●	
96	3360-81440	• PLUG	1	●	●	●	●	
97	2630-82140	SCREW	2	—	●	—	—	M5x50L
98	T2070-82410	LEVER	1	●	●	●	●	
99	T2070-82510	SPACER	1	●	●	●	●	
100	0263-90560	SCREW	2	●	●	—	—	M5x60L
101	0263-90550	SCREW	2	—	—	●	●	M5x50L
102	T2070-82000	CLEANER-A	1	●	●	—	—	
103	5731-82011	• HOUSING	1	●	●	—	—	
104	5730-82040	• COVER	1	●	●	—	—	
105	1751-82020	• FILTER	1	●	●	—	—	
106	5730-82060	• SLEEVE	2	●	●	—	—	
107	T2070-31111	COVER, FAN	1	●	●	●	●	
108	3310-12281	BOLT	4	●	●	●	●	M5x20L
109	T2070-32100	COVER-A	1	●	●	●	●	
110	1850-32160	SCREW	1	●	●	●	●	M4x12L
111	1900-31410	SCREW	2	●	●	●	●	TP4.5x18L
112	3699-91867	SPARKPLUG	1	●	●	●	●	NGK CMR7H
113	T2070-72200	SWITCH-A	1	●	●	●	●	
114	T2700-75410	LABEL, RECOIL	1	●	—	●	●	
115	T2701-75410	LABEL, RECOIL	1	—	●	—	—	
116	1726-85005	TANK-A	1	●	●	●	●	OP
117	5601-85201	• CAP-A	1	●	●	●	●	OP
118	1726-85601	• PIPE COMP	1	●	●	●	●	OP
119	5500-85400	• FILTER	1	●	●	●	●	OP
120	1260-85460	• CLIP	1	●	●	●	●	OP
121	1799-85400	PIPE COMP	1	●	—	●	●	
122	5500-85400	FILTER	1	●	—	●	●	
123	1260-85460	CLIP	1	●	—	●	●	
124	T3039-91310	SOCKET	1	●	●	●	●	
125	T2070-93112	MANUAL	1	●	●	●	●	
126	2890-96100	PULLER-A	1	●	●	●	●	OP
127	4810-96220	STOPPER	1	●	●	●	●	OP
128	848-ETZ-71T0	SPARKPLUG	1	●	●	●	●	OP (NGK CR8HIX with Terminal Nut)
129	1764-51220	SPRING	1	●	●	●	—	OP (5000rpm IN)
130	3699-91975	SPARKPLUG	1	●	●	●	●	OP (NGK CMR6H)
131	3699-91809	SPARKPLUG	1	●	●	●	●	OP (CHAMPION RZ7C)

11. Warranty

WARRANTY TERMS

1) Scope of Application

This engine manufactured by Husqvarna Zenoah Co., Ltd. (herein after “Zenoah”). And sold to the user directly or through distributor/manufacturer, shall entitle to be covered by this warranty.

2) Limits of Warranty

Zenoah warrants that;

1. The quality disclosed in the specifications.
2. The engine which shall be considered defective by Zenoah, caused by material or production fault.

3) Limits of Compensation

1. Zenoah compensates such quality, material and production faults by repairing or replacing through distributor/manufacturer.
2. Zenoah shall not compensate any other accompanied or benefit losses caused to user and distributor/manufacturer by such faults and through repairing or replacing.

4) Term of Warranty

Three (3) months after purchased by end- user subject to 12 months from produced month.

5) Exempt from Warranty

Zenoah shall not warrant this engine even if the fault has been caused during the period of terms of Warranty, in case that.

1. Any faults, failures caused from neglect of proper operation and maintenance described in OWNER’S MANUAL.
2. Any modification not approved by Zenoah.
3. Normal abrasion and deterioration.
4. Consuming parts.
5. Using any parts which have not been certified by Zenoah.
6. Add-on or modified use.



Husqvarna Zenoah Co., Ltd.

1-9 Minamidai, Kawagoe-city, Saitama, 350-1165 Japan

Phone: (+81)49-243-6917 Fax: (+81)49-243-7197