

Valiant 20cc

HANGAR 9

Instruction Manual
Bedienungsanleitung
Manuel d'utilisation
Manuale di Istruzioni



ARF



PNP
PLUG-N-PLAY

Scan the QR code and select the Parts and Support quick links from the product page for the most up-to-date manual information.
Scannen Sie den QR-Code und wählen Sie auf der Produktseite die Quicklinks Teile und Unterstützung, um die aktuellsten Informationen zu den Handbüchern zu erhalten.

Scannez le code QR et sélectionnez les liens rapides « Parts and Support » (Pièces et assistance) sur la page du produit pour obtenir les informations les plus récentes du manuel.

Scansionare il codice QR e nella pagina del prodotto selezionare li collegamenti rapidi a ricambi e assistenza per consultare le informazioni più aggiornate del manuale.

HORIZON
H O B B Y

NOTICE

All instructions, warranties and other collateral documents are subject to change at the sole discretion of Horizon Hobby, LLC. For up-to-date product literature, visit horizonhobby.com or www.towerhobbies.com and click on the support or resources tab for this product.

MEANING OF SPECIAL LANGUAGE

The following terms are used throughout the product literature to indicate various levels of potential harm when operating this product:

WARNING: Procedures, which if not properly followed, create the probability of property damage, collateral damage, and serious injury OR create a high probability of superficial injury.

CAUTION: Procedures, which if not properly followed, create the probability of physical property damage AND a possibility of serious injury.

NOTICE: Procedures, which if not properly followed, create a possibility of physical property damage AND a little or no possibility of injury.



WARNING: Read the ENTIRE instruction manual to become familiar with the features of the product before operating. Failure to operate the product correctly can result in damage to the product, personal property and cause serious injury.

This is a sophisticated hobby product. It must be operated with caution and common sense and requires some basic mechanical ability. Failure to operate this Product in a safe and responsible manner could result in injury or damage to the product or other property. This product is not intended for use by children without direct adult supervision. Do not attempt disassembly, use with incompatible components or augment product in any way without the approval of Horizon Hobby, LLC. This manual contains instructions for safety, operation and maintenance. It is essential to read and follow all the instructions and warnings in the manual, prior to assembly, setup or use, in order to operate correctly and avoid damage or serious injury.

Age Recommendation: Not For Children Under 14 Years. This Is Not A Toy.

SAFETY WARNINGS AND PRECAUTIONS

Read and follow all instructions and safety precautions before use. Improper use can result in fire, serious injury and damage to property.

Components

Use only with compatible components. Should any compatibility questions exist, please refer to the product instructions, component instructions or contact the appropriate Horizon Hobby office.

Flight

Fly only in open areas to ensure safety. It is recommended flying be done at radio control flying fields. Consult local ordinances before choosing a flying location.

Propeller

Always keep loose items that can become entangled in the propeller away from the prop. This includes loose clothing or other objects such as pencils and screwdrivers. Keep your hands away from the propeller as injury can occur.

Batteries

Always follow the manufacturer's instructions when using and disposing of any batteries. Mishandling of Li-Po batteries can result in fire causing serious injury and damage.

Small Parts

This kit includes small parts and should not be left unattended near children as choking and serious injury could result.

SAFE OPERATING RECOMMENDATIONS

- Inspect your model before every flight to ensure it is airworthy.
- Be aware of any other radio frequency user who may present an interference problem.
- Always be courteous and respectful of other users in your selected flight area.
- Choose an area clear of obstacles and large enough to safely accommodate your flying activity.
- Make sure this area is clear of friends and spectators prior to launching your aircraft.
- Be aware of other activities in the vicinity of your flight path that could cause potential conflict.
- Carefully plan your flight path prior to launch.
- Abide by any and all established AMA National Model Aircraft Safety Code.

BEFORE STARTING ASSEMBLY

- Remove parts from bag.
- Inspect fuselage, wing panels, rudder and stabilizer for damage.
- If you find damaged or missing parts, contact your place of purchase.
- Charge transmitter and receiver batteries.
- Center trims and sticks on your transmitter.
- For a computer radio, create a model memory for this particular model.
- Bind your transmitter and receiver, using your radio system's instructions.

NOTICE: Rebind the radio system once all control throws are set. This will keep the servos from moving to their endpoints until the transmitter and receiver connect. It will also guarantee the servo reversal settings are saved in the radio system.

IMPORTANT FEDERAL AVIATION ADMINISTRATION (FAA) INFORMATION



Use the QR code to learn more about the Recreational UAS Safety Test (TRUST), as was introduced by the 2018 FAA Reauthorization Bill. This free test is required by the FAA for all recreational flyers in the United States. The completed certificate must be presented upon request by any FAA or law enforcement official.



If your model aircraft weighs more than .55lbs or 250 grams, you are required by the FAA to register as a recreational flyer and apply your registration number to the outside of your aircraft. Use the QR code to learn more about registering with the FAA.



According to FAA regulation, all unmanned aircraft over .55lbs (250 grams), flying in United States airspace are required to either fly within an FAA-Recognized Identification Area (FRIA) or continually transmit an FAA-registered remote identification from a Remote ID broadcast module, such as the Spektrum™ Sky™ Remote ID module (SPMA9500). Use the QR code to learn more about the FAA Remote ID regulations.

TABLE OF CONTENTS

Notice.....	2
Meaning of Special Language.....	2
Safety Warnings and Precautions.....	2
Safe Operating Recommendations.....	2
Before Starting Assembly.....	2
Important Federal Aviation Administration (FAA) Information.....	2
Replacement Parts.....	3
Required for Completion (EP PNP).....	4
Required for Completion, Electric Motor Installation (ARF).....	4
Required for Completion, Gas Engine Installation (ARF).....	4
Required for Completion, Glow Engine Installation (ARF).....	4
Tools Required.....	4
Required Adhesives (ARF Version).....	4
Optional Items.....	4
Removing Wrinkles.....	5
Building Precautions.....	5
Transportation and Storage.....	5
Replacement Covering.....	5
Checking Blind Nuts.....	5
Aileron and Flap Servo Installation (ARF).....	5
Landing gear assembly (ARF).....	8
Landing gear installation (ARF and EP PNP).....	9
Elevator Control Horns Installation (ARF).....	9
Tail wheel and Rudder Control Horn (ARF).....	10
Electric Motor Installation (ARF).....	11
Gas Engine Installation (ARF).....	13
Fuel Tank Installation (ARF).....	15
Rudder and Elevator Servo Installation (ARF).....	15
Tail Surfaces Installation (ARF and EP PNP).....	16
Receiver Installation (ARF and EP PNP).....	18
Window Installation (ARF).....	18
Cowling installation (ARF).....	18
Spinner Installation (ARF and EP PNP).....	19
Wing Installation (ARF and EP PNP).....	19
Center of Gravity.....	20
Control Throws.....	21
Preflight Checklist.....	21
Daily Flight Checks.....	21
Limited Warranty.....	21
Warranty and Service Contact Information.....	22
WEEE NOTICE.....	22
Academy of Model Aeronautics National Model Aircraft Safety Code.....	23
Building and Flying Notes.....	23

REPLACEMENT PARTS

Item #	Description
HAN15041	Fuselage: Valiant 20cc
HAN15042	Wing Panel, LH: Valiant 20cc
HAN15043	Wing Panel, RH: Valiant 20cc
HAN15044	Stabilizer with Elevators: Valiant 20cc
HAN15045	Fin and Rudder: Valiant 20cc
HAN15046	Cowling: Valiant 20cc
HAN15047	Windshield Hatch: Valiant 20cc
HAN15048	Fuselage Top Hatch: Valiant 20cc
HAN15049	Hardware Set: Valiant 20cc
HAN15050	Wheel Set: Valiant 20cc
HAN15051	Wheel Pants: Valiant 20cc
HAN15052	Spinner: Valiant 20cc
HAN15053	EP Motor Box and ESC Mount: Valiant 20cc
HAN15054	Fuel Tank: Valiant 20cc
HAN15055	Engine Mount: Valiant 20cc
HAN15056	Main Landing Gear: Valiant 20cc
HAN15057	Tailwheel Assembly: Valiant 20cc
HAN15058	Window Set: Valiant 20cc
HAN15059	Decal Sheet: Valiant 20cc
HAN15060	16 x 8E Propeller
HAN15061	17 x 12E Propeller
HAN15062	Pushrod Set: Valiant 20cc
HAN15063	Wing Tube: Valiant 20cc
HAN15066	Float Strut Set
HAN15067	IC5 Device Mount Set with Hardware
HAN15068	Servo Arm Set (6) A6380 Double-Sided Arms
HAN-4408	Large Barbed Hinges (30)

REQUIRED FOR COMPLETION (EP PNP)

# Required	Item #	Description
1	SPM-1033	AR8360T+ Receiver
1	SPMX46S50	6S 4000mAh50C Smart G2 LiPo Battery: IC5

REQUIRED FOR COMPLETION, ELECTRIC MOTOR INSTALLATION (ARF)

# Required	Item #	Description
1	SPMXAM4770	Avian 5065-450Kv Brushless Outrunner Motor
1	SPMXAE1100	Avian 100A Smart ESC
1	SPM-1033	AR8360T+ Receiver
6	SPMSA6380	A6380 Standard Digital HV High Torque High Speed Metal Gear Aircraft Servo
2	SPMA3003	Servo Extension Lead: 12" Heavy-Duty
1	SPMX46S50	6S 4000mAh50C Smart G2 LiPo Battery: IC5

REQUIRED FOR COMPLETION, GAS ENGINE INSTALLATION (ARF)

# Required	Item #	Description
1	SAIEG21	FG-21 (1.26) 4-Stroke Gas Engine: BN
1	SPM-1033	AR8360T+ Receiver
7	SPMSA6380	A6380 Standard Digital HV High Torque High Speed Metal Gear Aircraft Servo
2	SPMA3003	Servo Extension Lead: 12" Heavy-Duty
1	SUL211	2' ProFlex Universal Fuel Line
1	APC13070	Sport Propeller, 13 x 7
1	SPMB1300LPRX	7.4V 1300mAh 2S 5C Li-Po Receiver Battery; JST-RCY
1	SPM9530	Switch Harness: 3-Wire

REQUIRED FOR COMPLETION, GLOW ENGINE INSTALLATION (ARF)

# Required	Item #	Description
1	SAIE125A	FA-125A AAC with Muffler: AG
1	SPM-1033	AR8360T+ Receiver
7	SPMSA6380	A6380 Standard Digital HV High Torque High Speed Metal Gear Aircraft Servo
2	SPMA3003	Servo Extension Lead: 12" Heavy-Duty
1	DUB222	Silicone Fuel Tubing, 2', Medium
1	APC13060	Sport Propeller, 13 x 6
1	SPMB1300LPRX	7.4V 1300mAh 2S 5C Li-Po Receiver Battery; JST-RCY
1	SPM9530	Switch Harness: 3-Wire

TOOLS REQUIRED

Description	
Box or open end wrench: 10mm, 7/16-inch, 1/2-inch	Light machine oil
Clamps	Low tack tape
Covering iron	Medium grit sandpaper
Drill	Mixing cups
Drill bit set, metric and english	Mixing sticks
Epoxy brushes	Pencil
Felt-tipped pen	Phillips screwdriver #0, #1, #2
Flat blade screwdriver	Pin vise
Flat file	Pliers
Flux paste	Razor saw
Heat gun	Ruler
Hemostats	Sanding drum for rotary tool
Hex wrench set, metric and english	Scissors
Hobby knife with #11 blade	Side cutter
Hobby scissors	Silver solder
Hobby square	Stepped reamer
Hook and loop tape	Toothpicks

REQUIRED ADHESIVES (ARF VERSION)

Description
15-minute epoxy
30-minute epoxy
Canopy glue
Thin CA
Medium CA
Threadlock, low strength

OPTIONAL ITEMS

# Required	Item #	Description
1	EFLA5600S	Float Set with Hardware, Silver; 39.5"
1	HAN15066	Float Strut Set: Valiant 20cc
1	EXRA055J	Charge Receptacle: JR/HRC/AIRZ
1	HAN99003	2 ³ / ₄ "-inch Aluminum Spinner P51

REMOVING WRINKLES

The covering of your model may develop wrinkles during shipping. Use a sealing iron (HAN1017) with a sealing iron sock (HAN1018) to remove them. Start with a lower heat setting and use caution while working around areas where the colors overlap to prevent separating the colors. It is also advised to use caution around the canopy as it is plastic and will distort with excessive heat. Avoid using too much heat, especially near seams, which could also separate the film. Placing a cool damp cloth on adjacent colors will also help prevent the separation of the colors while removing wrinkles. A heat gun can also be used, but with caution as it produces extreme heat and it is easy to damage the covering.

BUILDING PRECAUTIONS

Prepare the work surface prior to beginning the build. The surface should be soft and free of any sharp objects. We recommend resting the airframe parts on a soft towel or pit mat to prevent scratching or denting the surface of the aircraft.

TRANSPORTATION AND STORAGE

When transporting and storing your model, you will need a minimum of 72 in (1.8 m) in length, and 29 inches (74cm) in height to accommodate the size of the fuselage. We also recommend the use of wing bags to help protect these surfaces during transport and storage. The control horns and linkages can cause damage to other surfaces even when placed in storage bags. Always transport and store the wings so the linkages do not contact other panels to prevent damage.

REPLACEMENT COVERING

Your model is covered with UltraCote® film in the following colors. If repairs are required, order these coverings to make those repairs.

HANU870 White
HANU873 Deep Blue
HANU881 Silver

CHECKING BLIND NUTS

When building the aircraft, you will be required to thread machine screws into blind nuts. We recommend pre-threading the screws to make sure the blind nuts are clear of any debris. If the screws do not thread in easily, clear the threads using the appropriate tap and tap handle.

AILERON AND FLAP SERVO INSTALLATION (ARF)

1. Thread an M2 x 10mm self-tapping screw into each of the three holes for securing the aileron control horn to the aileron. Remove the screws before proceeding.
2. Apply 1–2 drops of thin CA in each hole to harden the surrounding wood. Allow the CA to fully cure before proceeding.
3. Secure the control horn to the aileron using three M2 x 10mm self-tapping screws and a #1 Phillips screwdriver.
4. Repeat the previous steps to install the flap control horn.
5. Center the servo using the radio system. Place the control horn on the servo so it is perpendicular to the servo. Remove any arms from the servo horn that will interfere with the operation of the servo.

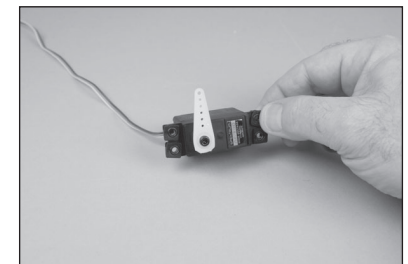
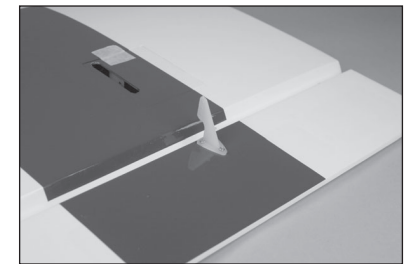
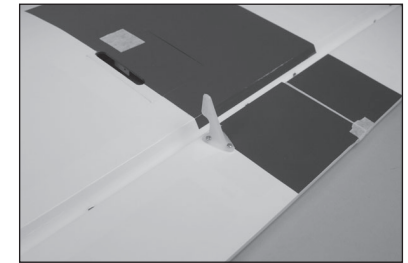
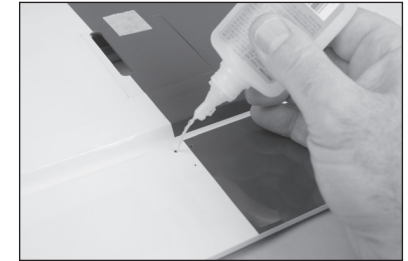
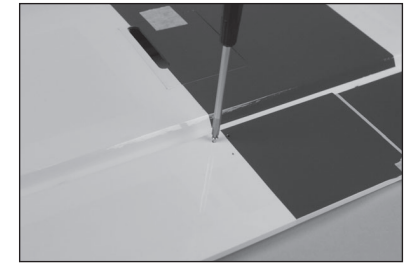

6. When attaching the linkage to the servo arm, use the hole that is 1 inch (25mm) from the center of the servo horn. This hole will need to be enlarged using a pin vise and 5/64-inch (2mm) drill bit.

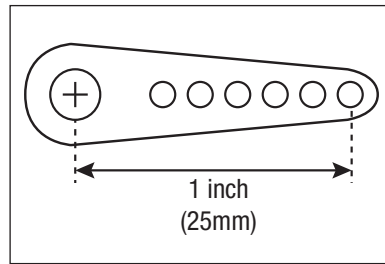

7. Secure a 12-inch (305mm) servo extension to the servo lead using a commercially available retainer (Servo Connector Clips, SPMA3054).

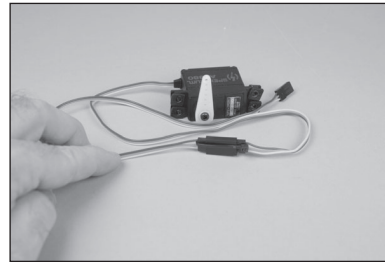

8. Use a pin vise or drill and 5/64-inch (2mm) drill bit to drill through the holes in the servo mount.

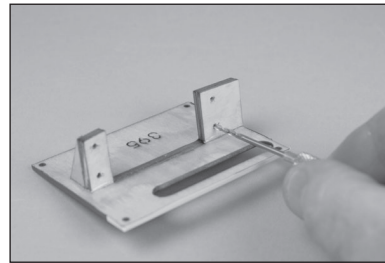

9. Thread a servo mounting screw into each hole, then remove the screws.

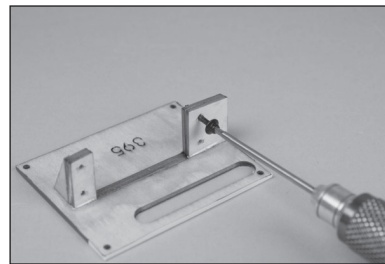

10. Apply 1–2 drops of thin CA in each hole to harden the surrounding wood. Allow the CA to fully cure before proceeding.

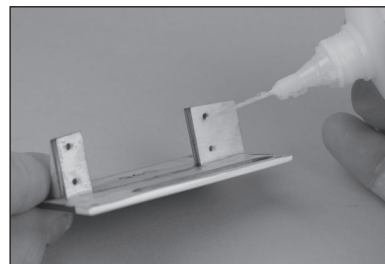

11. Position the servo with the servo output shaft centered in the opening for the servo arm. Mount the servo using the screws provided with the servo. Note the orientation of the servo on the servo cover.

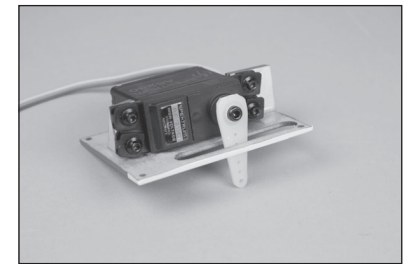

12. Use a toothpick or hobby knife with a #11 blade to puncture the servo cover for the mounting screws.

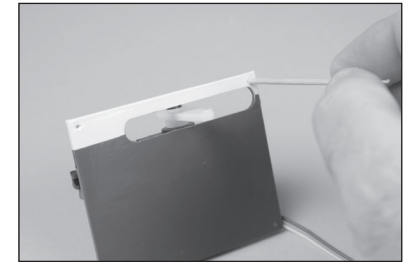

13. Thread an M2 x 10mm self-tapping screw into each of the holes for securing the aileron servo cover to the wing. Remove the screws before proceeding.

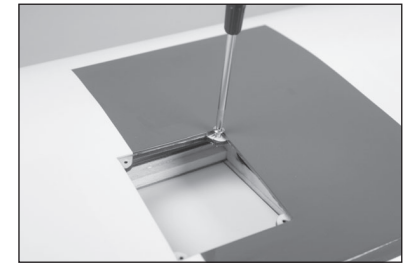

14. Apply 1–2 drops of thin CA in each hole to harden the surrounding wood. Allow the CA to fully cure before proceeding.



15. Tie or tape the string located inside the wing to the end of the servo lead.

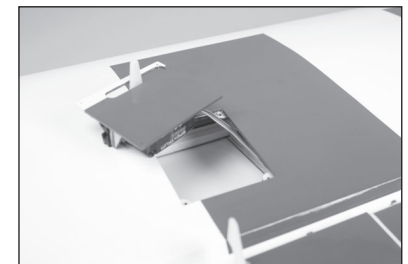

16. Guide the servo lead for the aileron through the wing to the wing root.

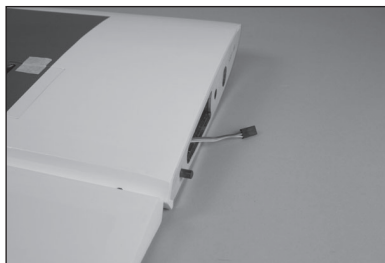

17. Secure the aileron servo cover using a #1 Phillips screwdriver and four M3 x 8mm self-tapping screws.

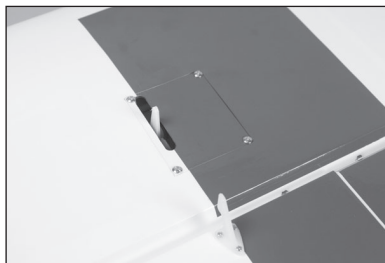

18. Repeat the previous steps to install the flap servo.

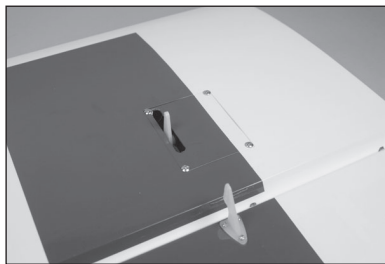

19. Retrieve the servo lead for the flap servo at the wing root. Label the aileron and flap servo leads so they can be easily identified when attaching the wing panels.

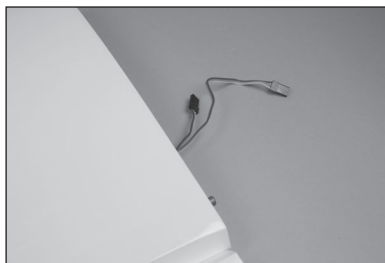

20. Insert the bend in the short pushrod into the hole in the servo arm indicated in Step 6.

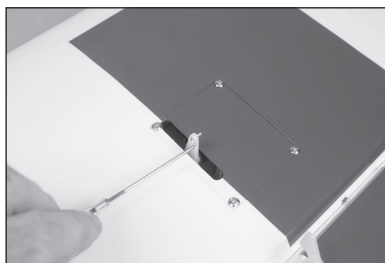

21. Rotate the linkage, inserting the bend in the arm.

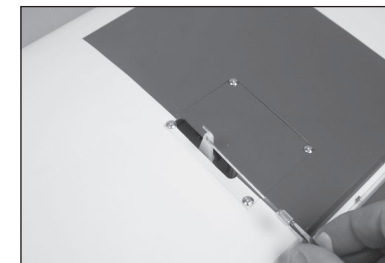

22. Use pliers to loosen the nut on the linkage that secures the clevis. Slide the clevis retainer back so the clevis can be easily opened.



23. Connect the clevis to the center hole of the control horn.

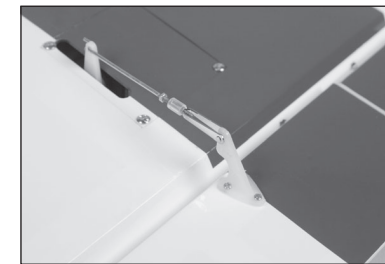

24. With the servo centered, thread the clevis in or out to align the aileron with the wing tip.



25. Once the aileron has been properly aligned, slide the silicone retainer over the clevis. Tighten the nut against the clevis to prevent it from vibrating loose, then apply a very small amount of medium-strength threadlock.

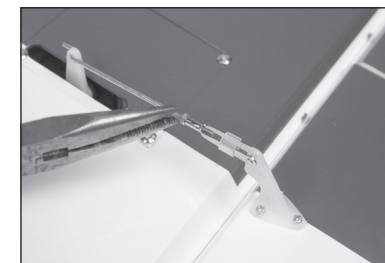

26. Repeat the previous steps to install the flap linkage, aligning the flap to the aileron, and the top of the fuselage at the inboard end.

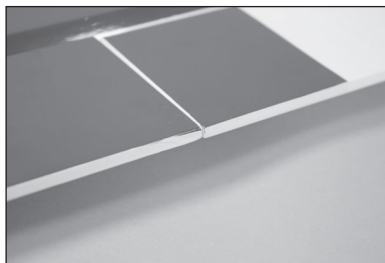

27. Once the flap has been properly aligned, slide the silicone retainer over the clevis. Tighten the nut against the clevis to prevent it from vibrating loose, then apply a very small amount of medium-strength threadlock.



28. Tie or tape the string located inside the wing to the end of the lighting lead..

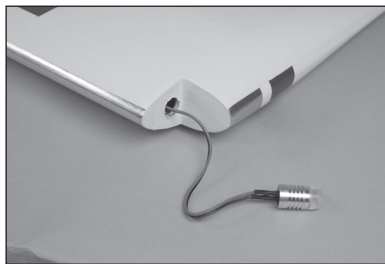

29. Retrieve the lead for the light at the wing root.

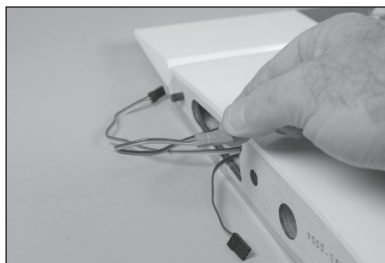

30. Use a small amount of silicone adhesive to glue the light in position.



31. The wing tip light lens is painted and shaped to fit either the left or right wing tip. Check the fit of the lenses to make sure they are in the correct locations. Use canopy glue to secure the lens to the wing tip. Low-tack tape is used to hold the lens in position until the adhesive fully cures.



LANDING GEAR ASSEMBLY (ARF)

32. Remove the wheel collars from the axle. Use a file to make two 1/2-inch (13mm) wide flat areas on the bottom of the axle. The first area is near the end of the axle, and the second is 1 1/4 inches (30mm) from the end of the axle.



33. Attach the axle to the landing gear using the washer and nut. Use two 1/2-inch wrenches to tighten the nut, securing the axle.

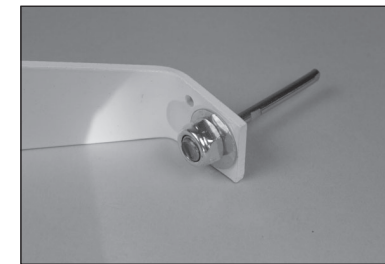

34. Ensure two opposing flats on the axle are aligned vertically as shown.



35. Slide a wheel collar on the axle. Place a drop light machine oil on the axle, then slide the wheel on the axle.



36. Secure the wheel using a wheel collar and M3 setscrew. Place a drop of thread lock on the threads of the setscrew before tightening it using a 1.5mm hex wrench. The wheel collar will be flush with the end of the axle.

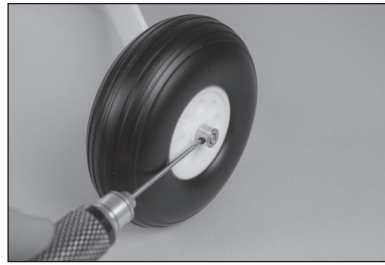

37. Slide the inner wheel collar against the wheel. Place a drop of thread lock on the threads of the 3mm setscrew before tightening it using a 1.5mm hex wrench. Check that the wheel rotates freely on the axle.



38. The landing gear has a tapered side, shown on the left in the photo. Place this side towards the rear of the airplane.



39. Attach the wheel pants to the landing gear using two M3 x 12 button head screws. Apply a drop of thread lock on the threads of each screw before tightening them using a 2mm hex wrench.



40. Repeat the previous steps for the remaining wheel and wheel pant installation.



LANDING GEAR INSTALLATION (ARF AND EP PNP)

- There are two mounting positions for the main landing gear. The forward position suits a wide range of surfaces and flying skill levels. The rear position is suitable for smooth surfaces, and will provide improved ground handling.
41. Attach the landing gear to the fuselage using four M4 x 12 socket head cap screws and four M4 washers. Apply a drop of thread lock on the threads of each screw before their installation. Tighten the screws using a 3mm hex wrench.

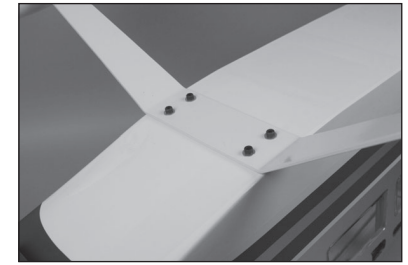

ELEVATOR CONTROL HORNS INSTALLATION (ARF)

42. Use a hobby knife with a #11 blade to separate the control horn back plate from the control horn.
43. Use a pin vise and 5/32-inch (2mm) drill bit to enlarge the holes in the control horn.
44. Use a toothpick or hobby knife and #11 blade to puncture the covering at the locations for the control horn screws on both the top and bottom of the elevator.

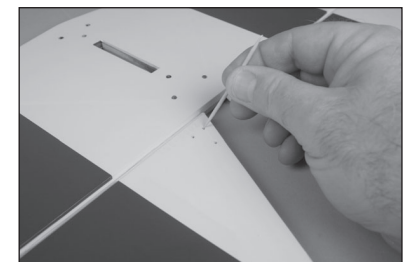
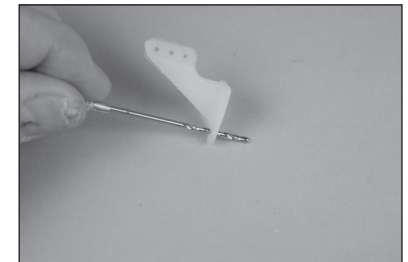
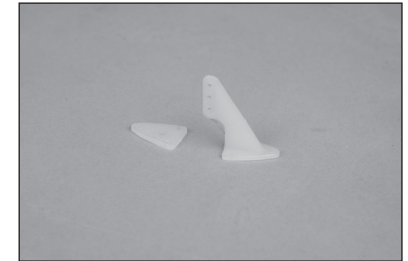

45. Insert the three M2 x 20mm machine screws through the control horn and into the holes in the elevator.

→ You can also install the screws with the head on the upper surface for a cleaner appearance.

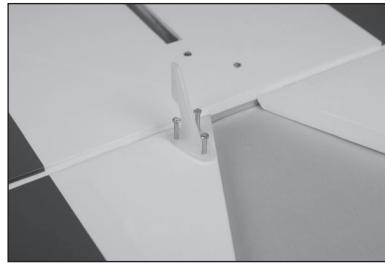

46. Place the back plate on the screws. Note the positioning of the back plate in relationship to the elevator.

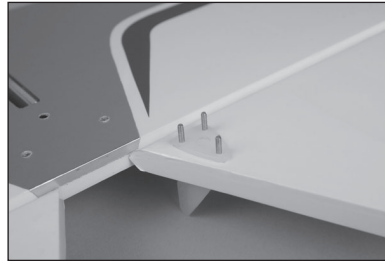

47. Thread an M2 nut on each screw. Tighten the nuts, avoiding crushing the underlying structure. Apply a drop of thin CA to a toothpick. Use the toothpick to apply the CA to the exposed threads of the screws.

→ Caution: Do not use threadlock on or near any plastic components.

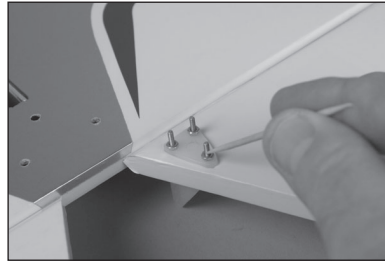

48. Use side cutters to trim the exposed screw thread. Use a flat file to carefully remove any sharp edges left from cutting the screws.



49. Repeat the previous steps for the remaining elevator control horn.



TAIL WHEEL AND RUDDER CONTROL HORN (ARF)

50. Loosen the setscrew in the wheel collar using a 1.5mm hex wrench. Slide the wheel collar against the coil and temporarily tighten the setscrew.

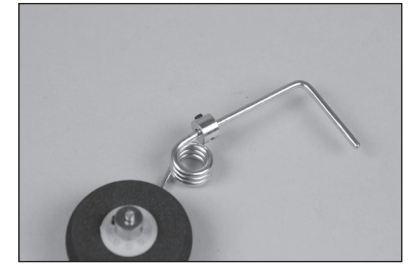

51. Test fit the tail wheel assembly to the rudder.

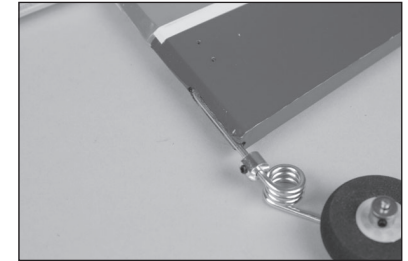

52. Remove the tail wheel assembly and sand the wire where it contacts the rudder. Use isopropyl alcohol to remove any debris or oils from the wire.

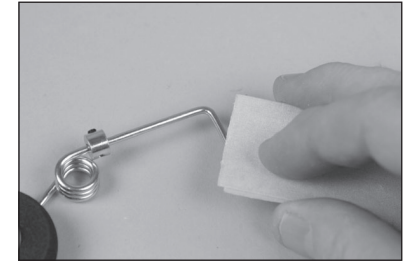

53. Slide the tail wheel bracket (small hole) onto the tail gear wire.

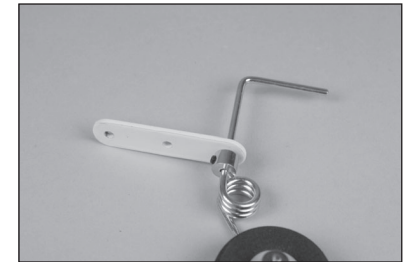

54. Apply a small amount of 30-minute epoxy to the tail wheel wire where it will contact the rudder.



55. Apply epoxy to the area of the rudder where the tail wheel wire fits into the rudder.

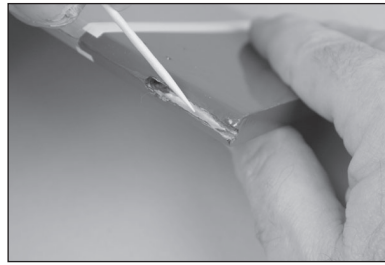

56. Fit the tail wheel wire in position. Use low-tack tape to hold the wire in position while the epoxy cures. Allow the epoxy fully cure before proceeding.



57. Install the rudder control horn using three M2 x 15mm machine screws and three M2 nuts. Use the instructions from the elevator control horn installation as a guide.

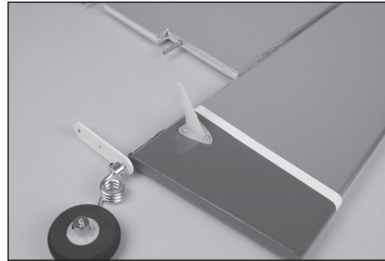

ELECTRIC MOTOR INSTALLATION (ARF)

58. Remove the windshield hatch from the fuselage. It is secured with magnet retainers. You may find it easier to grip each side of the windshield towards the top, and pull rearward. Another good method is to separate the top of the hatch with a thin plastic wedge.

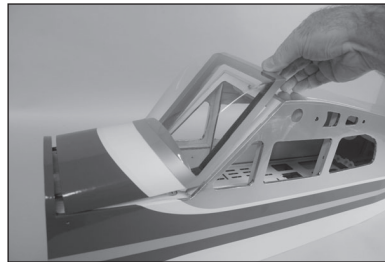

- Avoid picking at the top edge, as it may be possible to separate the windshield from the frame.

59. The top hatch has a spring-loaded latch located inside the fuselage at the rear. Release the hatch by pulling the latch pin forward, then pushing upwards.

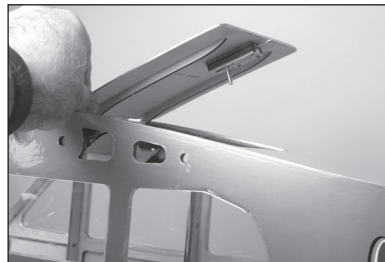

60. Apply hook and loop inside the fuselage. Mating hook and loop is used on the battery to keep the battery secure in the fuselage

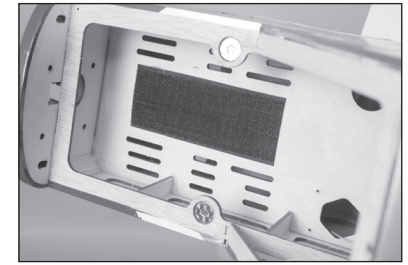

61. Install the two straps in the fuselage.

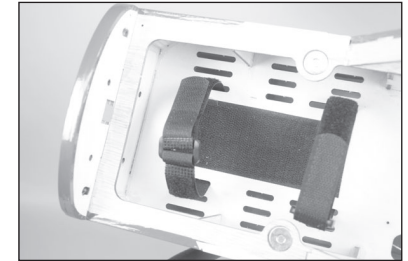

62. Use a #2 Phillips screwdriver to attach the X-mount to the rear of the motor. Use a 2.5mm hex wrench to attach the propeller adapter to the front of the motor. Use threadlock on all metal-to-metal fasteners to prevent them from vibrating loose.



63. Insert the motor wires into the top of the EP motor box.

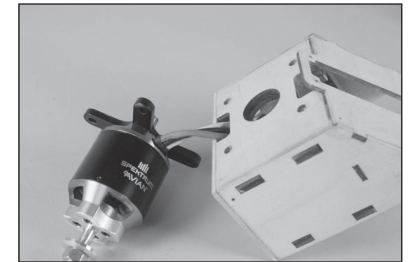

64. Connect the leads from the ESC to the motor.

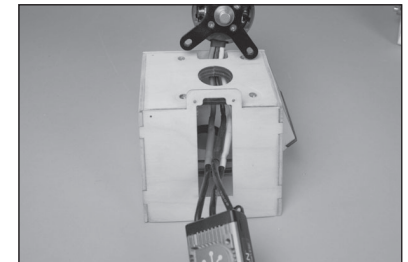

65. Apply a drop of threadlock on each of the four M4 x 20mm socket head cap screws. Secure the motor to the motor box using the four M4 x 20mm socket head cap screws and four M4 washers. Tighten the screws using a 3mm hex wrench.

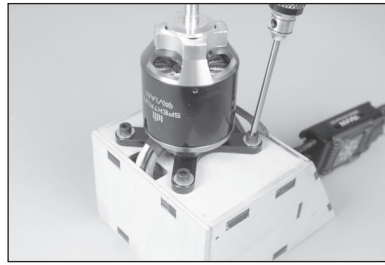

66. Secure the ESC to the bottom of the motor box using four M2 x 8mm self-tapping screws. Make sure to prepare the holes for the screws using thin CA as outlined earlier in this manual.

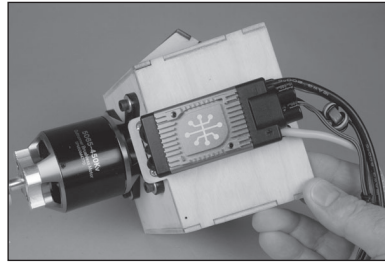

67. Position the motor box against the fuselage. Guide the connections for the ESC into the fuselage.

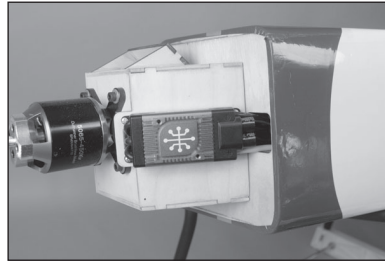

68. Attach the motor box to the fuselage using four M4 x 15mm socket head caps screws and washers. Tighten the screws using a 3mm hex wrench. Use threadlock on the screws to prevent them from vibrating loose.

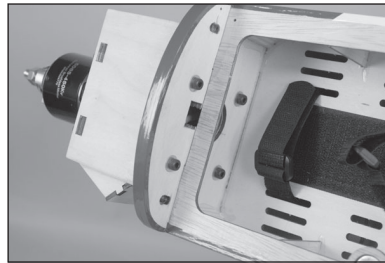

69. Mount the ESC connector mount to the plywood plate using two M2 x 8mm sheet metal screws. Tighten the screws using a #1 Phillips screwdriver.

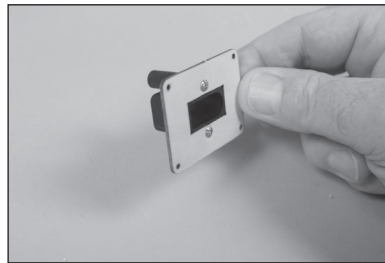

70. Insert the ESC IC5 plug in the mount. The connector will only fit correctly in one direction.

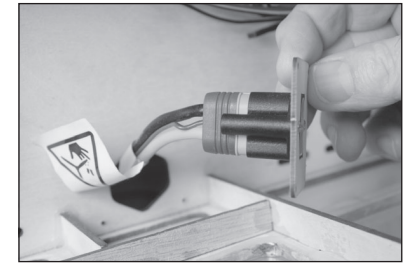

71. The IC5 retainer is secured to the mount using two M2.6 x 15mm self-tapping screws. The backplate will only fit correctly in one direction. Tighten the screws using a #2 Phillips screwdriver.

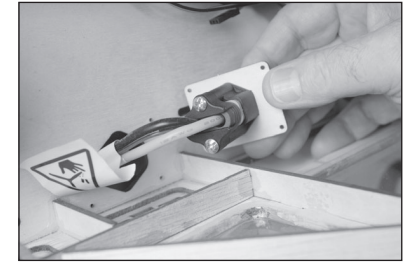

72. Secure the ESC connector assembly in the fuselage using two M2 x 10 sheet-metal screws. Tighten the screws using a #1 Phillips screwdriver. Make sure to prepare the holes for the screws in the fuselage using thin CA.

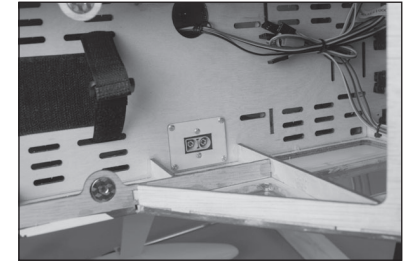

73. Mount the battery in the fuselage using hook and loop straps and hook and loop tape.

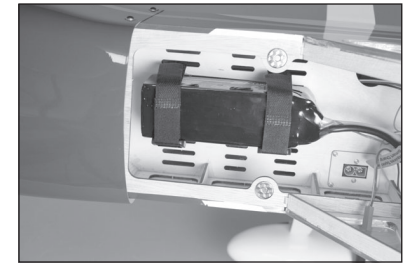

74. Remove the section of the covering on the bottom of the fuselage using a hobby knife and #1 blade. Glue the air exit to the bottom of the fuselage using silicone adhesive. Use low-tack tape to hold the exit in position until the adhesive fully cures.

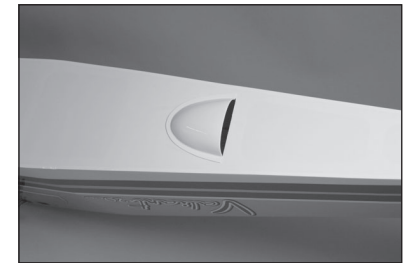

GAS ENGINE INSTALLATION (ARF)

75. Some engine options will require the use of the mounting template top drill the mounting holes in the firewall. Use a clamp to hold the template in position while marking the locations for the holes.

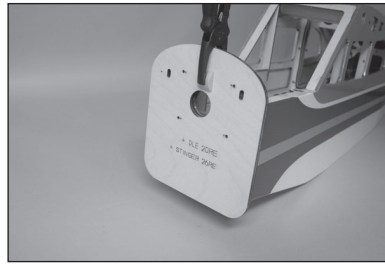

76. Use a drill and 7/32-inch (5.5mm) drill bit to drill the holes for the engine mount.

→ Enlarge the holes using a drill and 7/32-inch (5.5mm) drill bit if the template is not required for your particular engine.



77. Place an M4 locking washer on an M4 x 20mm socket head screw included with the engine. Prepare four screws at this time.



78. Attach the mount to the firewall using the four M4 x 20 socket head screws prepared in the previous step and four M4 blind nuts. Tighten the screws using a 3mm hex wrench.

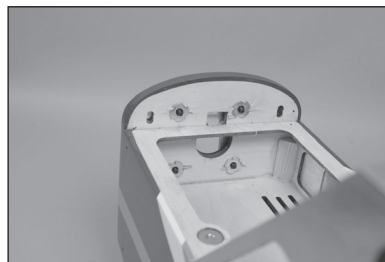
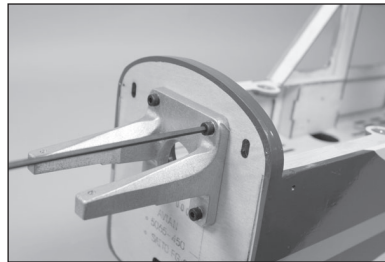

79. Attach the clevis from the throttle pushrod to the carburetor arm. Temporarily attach the engine to the engine mount using two M4 x 15mm socket head cap screws. Mark the firewall using a felt-tipped pen in the location of the clevis.

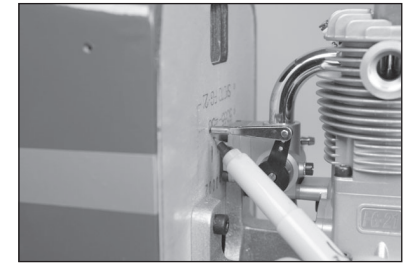

80. Use a drill and 7/32-inch (5.5mm) drill bit to drill the hole for the throttle pushrod.



81. Insert the pushrod and pushrod tube into the fuselage.



82. Retrieve the pushrod tube inside the fuselage, routing it through the slot in the radio tray.

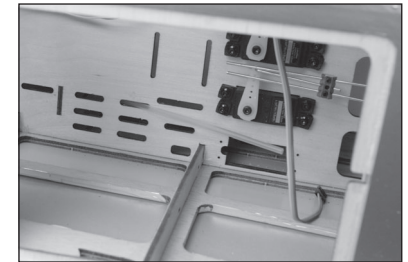

83. Thread the clevis on the throttle pushrod.

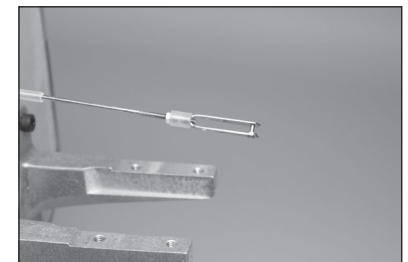

- 84.** Connect the clevis to the carburetor arm. Mount the engine to the engine mount using four M4 x 15 socket head cap screws and four M4 locking washers. Tighten the screws using a 3mm hex wrench.

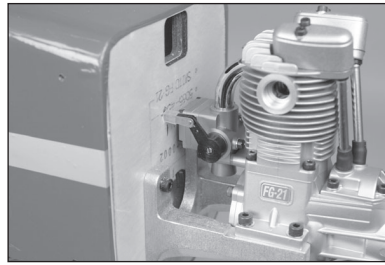

- Check the operation of the carburetor and that the clevis can move freely through the hole in the firewall. The pushrod tube will rest inside the fuselage for the carburetor to operate properly.

- 85.** Mark the pushrod tube 1/8-inch (3mm) beyond the slot toward the rear of the fuselage.



- 86.** Slide the pushrod tube over the pushrod wire. Use side cutters to trim the tube at the mark made in the previous step.

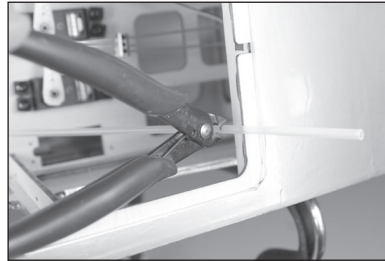

- 87.** Roughen 1 inch (25mm) of the end of the pushrod tube using medium grit sandpaper. List the tube back in position. Check that the carburetor can fully close without hitting the tube near the firewall.

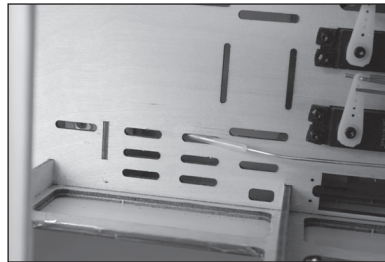

- 88.** Use a small amount of 5-minute epoxy to glue the tube to the radio tray. Rotate the tube to evenly distribute the epoxy around the tube and radio tray. Allow the epoxy to fully cure before proceeding.

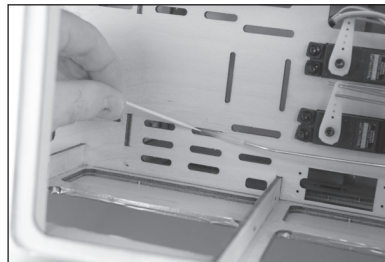

- 89.** Mount the throttle servo in the radio tray with the output facing the rear of the fuselage.



- 90.** Mount the throttle servo connector in the throttle servo arm. Place a drop of canopy glue on the M2 nut, then install it on the underside of the arm to secure the connector.

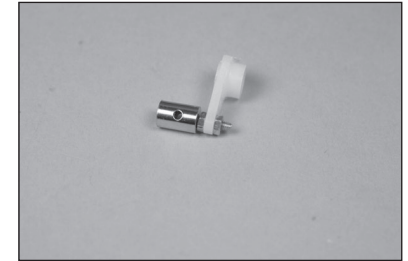

- 91.** With the throttle stick and trim still centered, pass the throttle pushrod through the connector, then place the servo arm on the servo.



- 92.** Manually close the carburetor. Move the throttle stick to closed throttle. Tighten the setscrew to secure the pushrod in the connector. Secure the servo arm using the hardware provided with the servo. Check the operation of the carburetor to make sure it opens fully, and the pushrod does not bind. Make any necessary adjustment to the linkage or in the radio programming as needed.



- 93.** Trim the excess pushrod wire using side cutters.



FUEL TANK INSTALLATION (ARF)

94. Fit a 12 inch (305mm) piece of fuel tubing on the nipple of the fuel tank. Secure the tubing using a tubing clip.

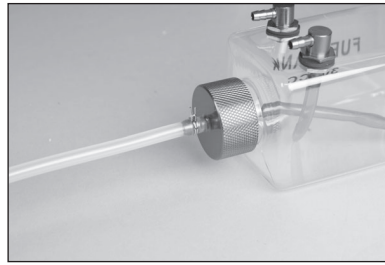

95. Mount the fuel tank in the fuselage using two long zip ties or hook and loop straps. A piece of foam under the fuel tank will help keep it in place. (not included).

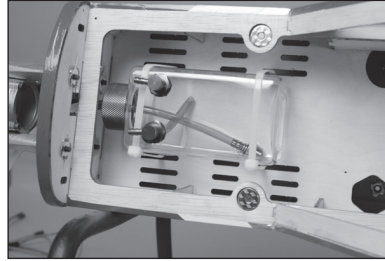

96. Route the fuel line to the carburetor. Secure the fuel line using a tubing clip.

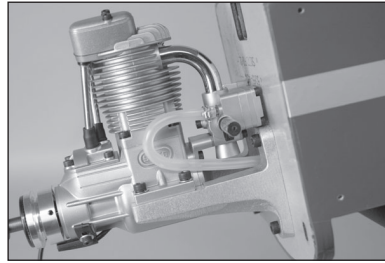

97. Mount the ignition module in the fuselage using hook and loop tape. Make the connections to the spark plug and sensor. Secure the sensor connection using the clip included with the engine.

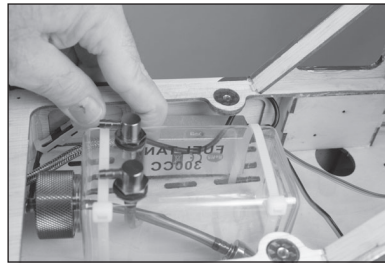

98. Mount the ignition battery in the fuselage. Install a switch on the side of the fuselage between the battery and ignition module. Secure all connections using commercially available retainers (Servo Connector Clips, SPMA3054)



RUDDER AND ELEVATOR SERVO INSTALLATION (ARF)

99. Center the rudder and elevator servos using the radio system. Place the control horns on the servos so they are perpendicular to the servo. Remove any arms from the servo horns that will interfere with the operation of the servo.

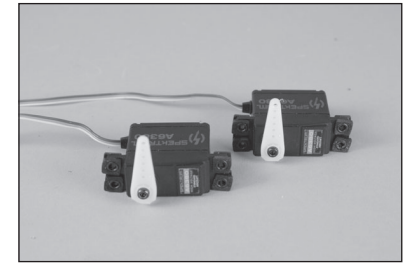

100. When attaching the linkage to the servo arm, use the hole that is 1 inch (25mm) from the center of the servo horn. This hole will need to be enlarged using a pin vise and 5/64-inch (2mm) drill bit.

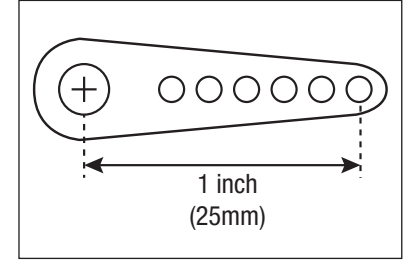

101. Mount the rudder and elevator servo in the fuselage with the servo outputs facing the front of the fuselage. Make sure to prepare the holes for the servo mounting screws using the methods outlined earlier in this manual.

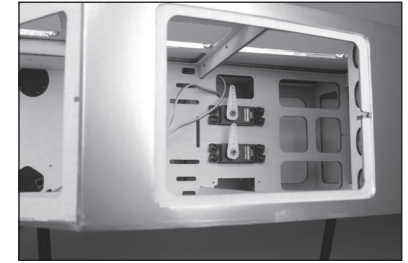

102. Prepare the forward elevator pushrod by placing it in the joiner with 1/4 inch (4mm) of the pushrod exposed beyond the joiner. Tighten the setscrew to secure the wire in the joiner with the Z-bend facing away from the setscrew.

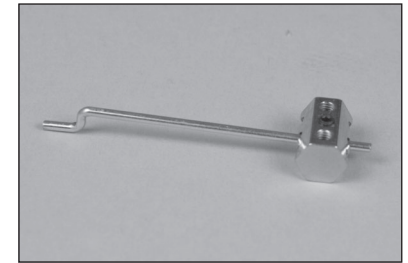

103. Insert the Z-bend into the servo arm for the elevator servo. The setscrew locations must face toward the top of the fuselage so they can be accessed easily.

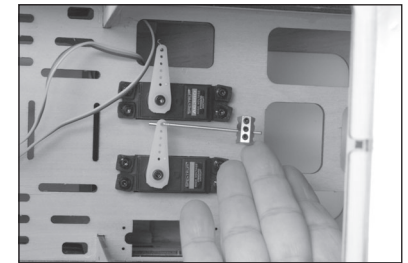

104. Remove the clevises and nuts from the straight elevator pushrods (The rudder pushrod has a Z-bend.)

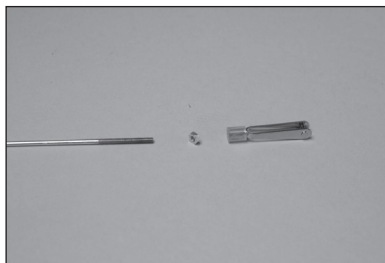

105. Insert both elevator pushrods into the pushrod tubes. The pushrods are on either side of the forward elevator pushrod in the joiner. Temporarily tighten the setscrews to the elevator pushrods.

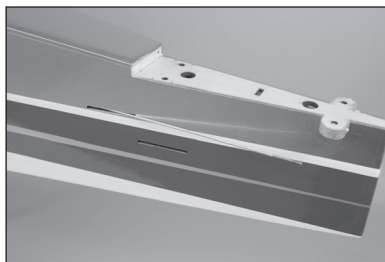
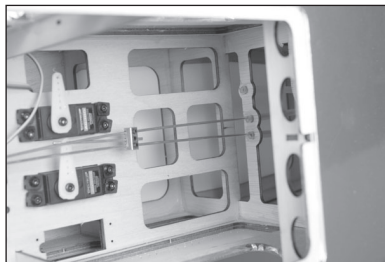

106. Thread the nut and clevis back on the elevator joiner wires.



107. Remove the clevis and nut from the rudder pushrod. Remove the servo arm from the rudder servo and attach the Z-bend from the rudder pushrod to the rudder servo arm.

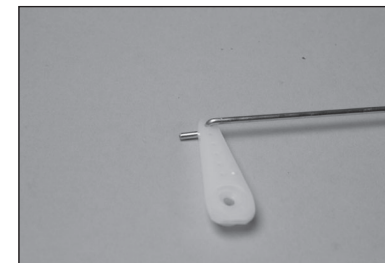

108. Insert the rudder pushrod into the pushrod tube, then secure the servo arm back to the rudder servo.

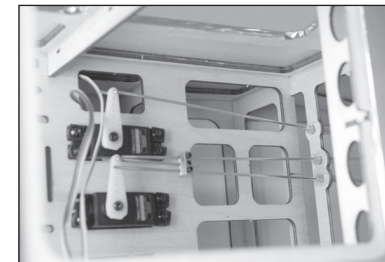

109. Thread the nut and clevis back on the rudder rod.

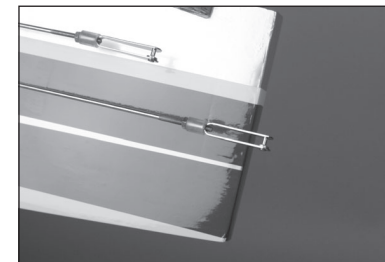

TAIL SURFACES INSTALLATION (ARF AND EP PNP)

110. Fit the fin into the slot in the stabilizer.

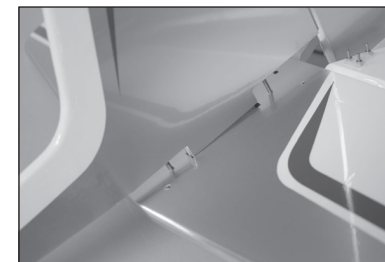

111. The fin must rest flush against the stabilizer when installed correctly.

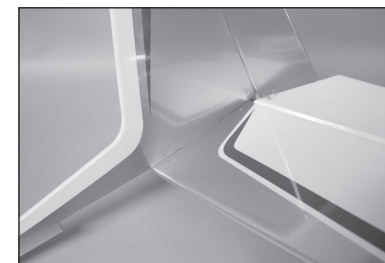

112. Use two M3 washers and two M3 nuts to secure the fin to the stabilizer. Use a 4mm nut driver to tighten the nuts.

→ Don't tighten the nuts excessively. Use just enough torque to seat the fin fully, and so the washers barely compress the stabilizer film and underlying wood.

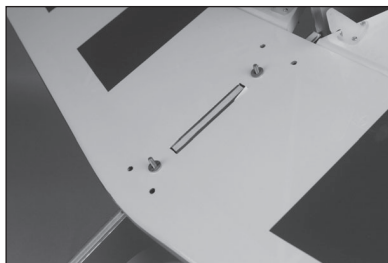

113. Fit the tail assembly to the fuselage. The stabilizer will rest flat against the fuselage when installed correctly.



114. Use four M3 washers and four M3 x 20mm socket head cap screws to secure the tail assembly to the fuselage. Tighten the screws using a 2.5mm hex wrench.

→ Don't tighten the nuts excessively. Use just enough torque to seat the fin fully, and so the washers barely compress the stabilizer film and underlying wood.

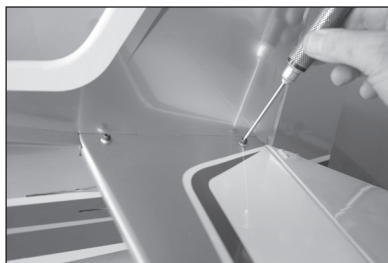

115. Secure the tail wheel bracket to the fuselage using two M3 x 8mm self-tapping screws. Tighten the screws using a #2 Phillips screwdriver.



116. Slide the wheel collar against the bracket. Apply a small amount of medium threadlock to the setscrew. Tighten the setscrew using a 1.5mm hex wrench.

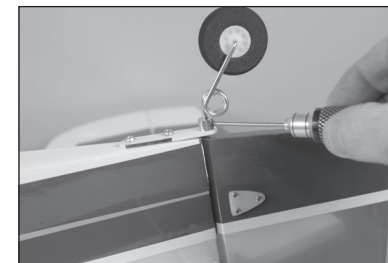

117. Connect the clevis to the middle hole of the elevator control horns.

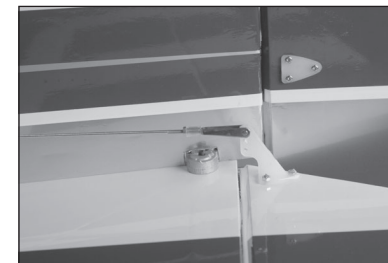

118. Use a ruler to align the elevator to the stabilizer.

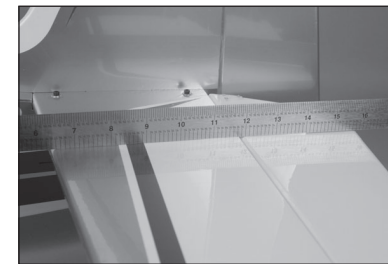

119. With the radio on and the elevator servo centered, tighten the setscrew to the elevator pushrod while holding the elevator centered. Repeat this process for both elevator halves. Once aligned, slide the clevis retainer over the clevis and tighten the nuts against the clevises.

→ Making sure both elevator halves are perfectly aligned is necessary to allow accurate trimming of the model in flight.

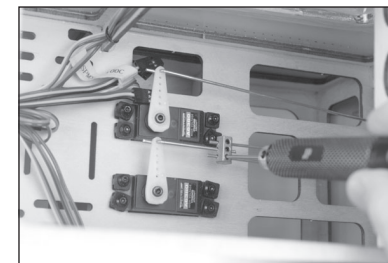

120. Connect the clevis to the outer hole of the rudder control horn. Adjust the clevis to center the rudder while the radio system is on and the rudder servo is centered. Once adjusted, slide the clevis retainer over the forks of the clevis and tighten the nut against the clevis.

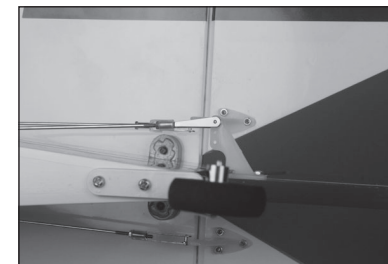

RECEIVER INSTALLATION (ARF AND EP PNP)

121. Route the leads for the ailerons, flaps and lighting from the receiver up and out of the fuselage.



122. Use tie wraps to secure the leads to the fuselage structure. Make sure the leads are on the edge of the structure so the windows can be installed.



123. Mount the receiver using double-sided adhesive foam or gel tape. Connect the leads and extensions for the servos to the appropriate channels of the receiver.

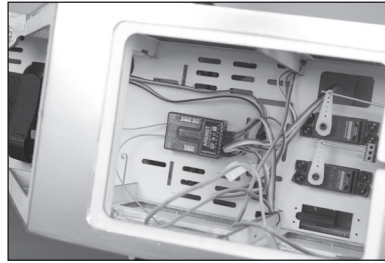

124. When using the recommended AR8360T+ receiver, select the Two Ailerons Two Flaps wing configuration, and use the port assignments in the table.

Receiver	Channel
1	Throttle
2	Right Aileron
3	Elevator
4	Rudder
5	Left Flap
6	Left Aileron
7	Right Flap

WINDOW INSTALLATION (ARF)

125. Use hobby scissors to trim the six window sections as necessary to fit in the fuselage openings..

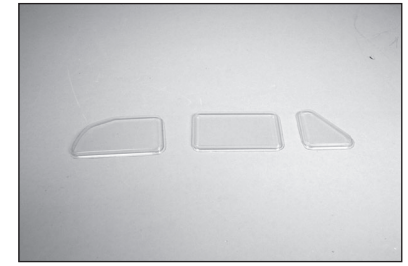

126. Use canopy glue to secure the windows inside the fuselage. Use low-tack tape to hold the windows in position until the adhesive fully cures.

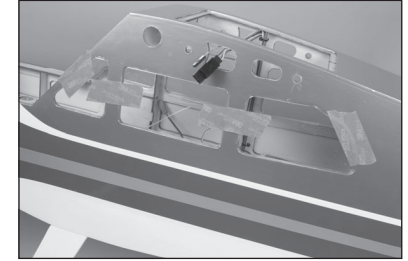

COWLING INSTALLATION (ARF)

127. Cut four pieces of card stock that are 1/2 x 2 inches (13 x 51mm). Make a 1/8-inch (3mm) hole in each piece. Tape the card stock to the fuselage with the hole aligned with the blind nut in the fuselage.

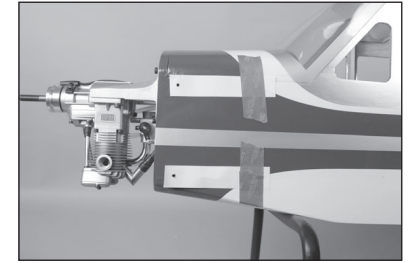

128. Slide the cowling on the fuselage, making sure the card stock markers are on the outside of the cowling. (The cowling may require trimming to fit over the engine components). With the backplate pressed tightly against the engine driver washer, position the cowling so there is a 1/16-inch (1.5mm) gap between the backplate and cowling. Also make sure the cowling is aligned with the backplate. Use low-tack tape to keep the cowling attached to the fuselage for the following steps.



129. Use a felt-tipped pen to mark the holes on the cowling using the paper templates as a guide.

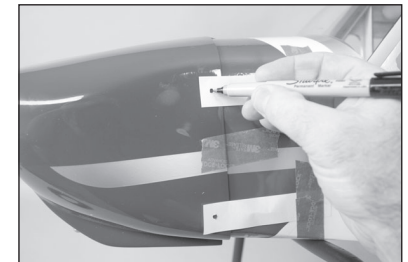

130. Remove the cowling from the fuselage and drill the locations using a pin vise and 1/8-inch (3mm) drill bit.

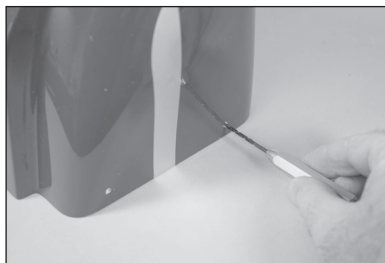

131. Attach the muffler to the engine using the hardware included with the engine. Follow any instructions included with the engine for the muffler installation and any other connections necessary for the operation of your engine. Fit the cowling to the fuselage. Trim the cowling as necessary to fit around the muffler.

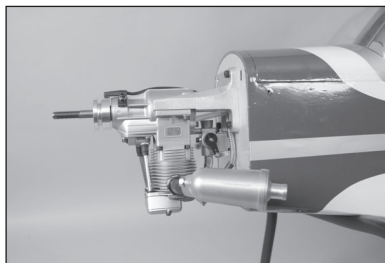

132. Secure the cowling using four M3 washers and four M3 x 10mm button head screws to secure the cowling to the fuselage. Use a 2.5mm hex wrench to tighten the screws.

- Use a drop of canopy glue on each screw to keep them from vibrating loose in flight, this will also allow easy removal of the screws if access to the engine is required in the future.

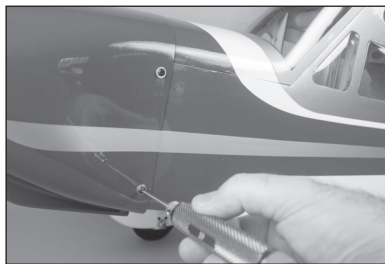

SPINNER INSTALLATION (ARF AND EP PNP)

133. Use a small amount of medium CA to attach a sandpaper disk to the front of the spinner backplate, aligning the hole in the disk with the hole in the backplate. The smooth side of the disk will be against the spinner backplate.



134. Use a small amount of medium CA to attach a sandpaper disk to the back of the propeller, aligning the hole in the disk with the hole in the propeller. The smooth side of the disk will be against the propeller.

- The disks create friction between the propeller and spinner backplate so the propeller can be tightened without slipping.

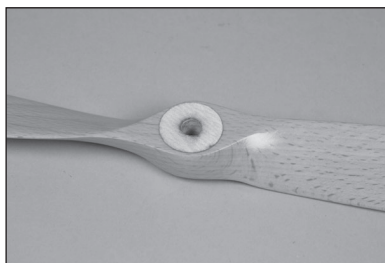

135. Slide the spinner backplate in position.



136. Attach the propeller using the washer and nut from the engine. Use a box wrench to prevent damaging the nut.



137. Check the alignment of the spinner cone to the propeller. There must be an equal gap between the cutout of the spinner cone and the propeller. Repeat the previous step to reposition the propeller if needed.

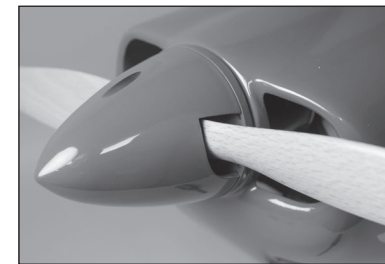

138. Attach the spinner cone using the hardware included with the spinner.

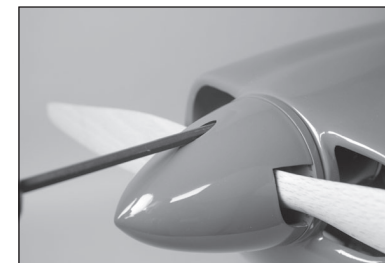

WING INSTALLATION (ARF AND EP PNP)

139. Slide the wing tube into the wing tube socket.

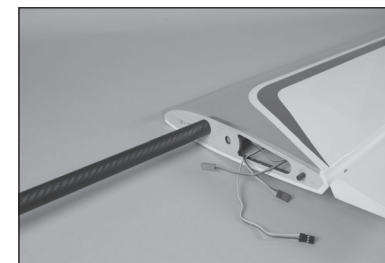

140. Slide the wing tube in the socket in the fuselage. Connect the leads for the aileron, flap and lighting.

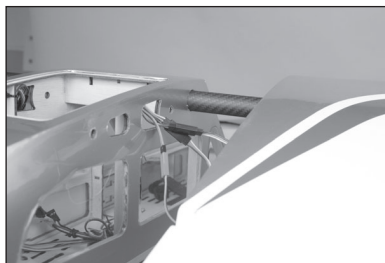

141. Slide the wing panel tight against the fuselage, guiding the wiring into the fuselage.

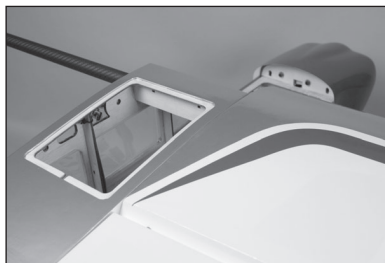

142. Secure the wing panel using the 1/4-20 nylon wing bolt.

- ➔ The wing retaining bolts can be trimmed shorter if desired.
- ➔ Repeat the previous step to install the remaining wing panel.



CENTER OF GRAVITY

 **CAUTION:** You must adjust your aircraft's center of gravity and balance your model properly before attempting flights.

An important part of preparing the aircraft for flight is properly balancing the model. The Center of Gravity range supplied here is a guideline based on testing. Deviation from the measurements we provide is possible and may result in a model that suits your flying style better. Start with the recommended Center of Gravity, then feel free to experiment with different balance points. We advise adjusting progressively and cautiously.

1. Attach the wing panels to the fuselage. Make sure to connect the leads from the aileron and flaps to the appropriate leads from the receiver. Make sure the leads are not exposed outside the fuselage before tightening the wing bolts. Your model should be flight-ready before balancing.
 2. The recommended Center of Gravity (CG) location for your model is $3\frac{3}{8}$ inches (85mm) behind the leading edge of the wing against the fuselage for sport flying.
 3. When balancing your model, make sure it is assembled and ready for flight. Support the plane upright at the marks made on the wing with your fingers or a commercially available balancing stand. Use the radio system to move the gear to the up position.
- ➔ The overall CG range for this model is $3\frac{1}{8}$ –4 inches (78–102mm) as shown below. We recommend starting at the measurement listed above, then adjusting to suit your particular flying style.
 - ➔ Nose weight may be required when using lighter engines or when floats are installed.

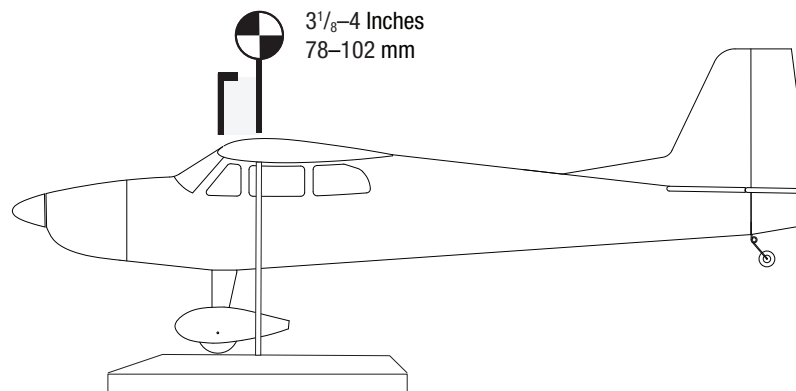

CONTROL THROWS

1. Turn on the transmitter and receiver of your model. Check the movement of the rudder using the transmitter. When the stick is moved to the right, the rudder should also move right. Reverse the direction of the servo at the transmitter if necessary.
2. Check the movement of the elevator with the radio system. Moving the elevator stick toward the bottom of the transmitter will make the airplane elevator move up.
3. Check the movement of the ailerons with the radio system. Moving the aileron stick to the right will make the right aileron move up and the left aileron move down.

Use a ruler to adjust the throw of the elevator, ailerons and rudder.

Surface	Rate	Direction	Throw
Aileron	High	Up	1 ¹ / ₄ inches (32 mm)
		Down	1 ¹ / ₄ inches (32 mm)
	Mid	Up	7/8 inches (22 mm)
		Down	7/8 inches (22 mm)
Elevator	High	Up	1 ⁷ / ₈ inches (48 mm)
		Down	1 ⁷ / ₈ inches (48 mm)
	Low	Up	1 ¹ / ₄ inches (32 mm)
		Down	1 ¹ / ₄ inches (32 mm)
Rudder	High	Left	1 ¹⁵ / ₁₆ inches (50 mm)
		Right	1 ¹⁵ / ₁₆ inches (50 mm)
	Low	Left	1 ³ / ₈ inches (35 mm)
		Right	1 ³ / ₈ inches (35 mm)
Flaps	Partial	1 ³ / ₈ inches (35 mm)	
	Full	2 ³ / ₄ inches (70 mm)	

These are guidelines from general flying from our own flight tests. You can experiment with higher or lower rates to match your preferred style of flying.

Travel Adjust should be adjusted according to each individual model and preference. Always install the servo arms 90 degrees to the pushrod at the servo. Use sub-trim as a last resort to center the servos.

Always re-bind the radio system once all the control throws are set to keep the servos from moving to their endpoints until the transmitter and receiver connect.

PREFLIGHT CHECKLIST

- Charge the transmitter, receiver and motor batteries. Follow the instructions provided with the charger. Follow all manufacturer's instructions for your electronic components.
- Check the radio installation and make sure all control surfaces (aileron, elevator, rudder, and flaps) move correctly (i.e., the correct direction and with the recommended throws).
- Check all the hardware (control horns, servo horns, and clevises) to make sure they are secure and in good condition.
- Prior to each flying session (and especially with a new model), perform a range check of your radio system. See your radio manual for the recommended range and instructions for your particular radio system.

DAILY FLIGHT CHECKS

- Check the battery voltage of the transmitter battery. Do not fly below the manufacturer's recommended voltage. Doing so can cause your aircraft to crash.
- Check all hardware (linkages, screws, nuts, and bolts) prior to each day's flight. Ensure that binding does not occur and that all parts are properly secured.
- Ensure all surfaces are moving in the proper manner.
- Perform a ground range check before each day's flying session.
- All servo leads and switch harness plugs should be secured in the receiver.

LIMITED WARRANTY

What this Warranty Covers

Horizon Hobby, LLC, (Horizon) warrants to the original purchaser that the product purchased (the "Product") will be free from defects in materials and workmanship at the date of purchase.

What is Not Covered

This warranty is not transferable and does not cover (i) cosmetic damage, (ii) damage due to acts of God, accident, misuse, abuse, negligence, commercial use, or due to improper use, installation, operation or maintenance, (iii) modification of or to any part of the Product, (iv) attempted service by anyone other than a Horizon Hobby authorized service center, (v) Product not purchased from an authorized Horizon dealer, (vi) Product not compliant with applicable technical regulations, or (vii) use that violates any applicable laws, rules, or regulations.

OTHER THAN THE EXPRESS WARRANTY ABOVE, HORIZON MAKES NO OTHER WARRANTY OR REPRESENTATION, AND HEREBY DISCLAIMS ANY AND ALL IMPLIED WARRANTIES, INCLUDING, WITHOUT LIMITATION, THE IMPLIED WARRANTIES OF NON-INFRINGEMENT, MERCHANTABILITY AND FITNESS FOR A PARTICULAR PURPOSE. THE PURCHASER ACKNOWLEDGES THAT THEY ALONE HAVE DETERMINED THAT THE PRODUCT WILL SUITABLY MEET THE REQUIREMENTS OF THE PURCHASER'S INTENDED USE.

Purchaser's Remedy

Horizon's sole obligation and purchaser's sole and exclusive remedy shall be that Horizon will, at its option, either (i) service, or (ii) replace, any Product determined by Horizon to be defective. Horizon reserves the right to inspect any and all Product(s) involved in a warranty claim. Service or replacement decisions are at the sole discretion of Horizon. Proof of purchase is required for all warranty claims. SERVICE OR REPLACEMENT AS PROVIDED UNDER THIS WARRANTY IS THE PURCHASER'S SOLE AND EXCLUSIVE REMEDY.

Limitation of Liability

HORIZON SHALL NOT BE LIABLE FOR SPECIAL, INDIRECT, INCIDENTAL OR CONSEQUENTIAL DAMAGES, LOSS OF PROFITS OR PRODUCTION OR COMMERCIAL LOSS IN ANY WAY, REGARDLESS OF WHETHER SUCH CLAIM IS BASED IN CONTRACT, WARRANTY, TORT, NEGLIGENCE, STRICT LIABILITY OR ANY OTHER THEORY OF LIABILITY, EVEN IF HORIZON HAS BEEN ADVISED OF THE POSSIBILITY OF SUCH DAMAGES. Further, in no event shall the liability of Horizon exceed the individual price of the Product on which liability is asserted. As Horizon has no control over use, setup, final assembly, modification or misuse, no liability shall be assumed nor accepted for any resulting damage or injury. By the act of use, setup or assembly, the user accepts all resulting liability. If you as the purchaser or user are not prepared to accept the liability associated with the use of the Product, purchaser is advised to return the Product immediately in new and unused condition to the place of purchase.

Law

These terms are governed by Illinois law (without regard to conflict of law principals). This warranty gives you specific legal rights, and you may also have other rights which vary from state to state. Horizon reserves the right to change or modify this warranty at any time without notice.

WARRANTY SERVICES

Questions, Assistance, and Services

Your local hobby store and/or place of purchase cannot provide warranty support or service. Once assembly, setup or use of the Product has been started, you must contact your local distributor or Horizon directly. This will enable Horizon to better answer your questions and service you in the event that you may need any assistance. For questions or assistance, please visit our website at www.horizonhobby.com, submit a Product Support Inquiry, or call the toll free telephone number referenced in the Warranty and Service Contact Information section to speak with a Product Support representative.

Inspection or Services

If this Product needs to be inspected or serviced and is compliant in the country you live and use the Product in, please use the Horizon Online Service Request submission process found on our website or call Horizon to obtain a Return Merchandise Authorization (RMA) number. Pack the Product securely using a shipping carton. Please note that original boxes may be included, but are not designed to withstand the rigors of shipping without additional protection. Ship via a carrier that provides tracking and insurance for lost or damaged parcels, as Horizon is not responsible for merchandise until it arrives and is accepted at our facility. An Online Service Request is available at http://www.horizonhobby.com/content/service-center_render-service-center. If you do not have internet access, please contact Horizon Product Support to obtain a RMA number along with instructions for submitting your product for service. When calling Horizon, you will be asked to provide your complete name, street address, email address and phone number where you can be reached during business hours. When sending product into Horizon, please include your RMA number, a list of the included items, and a brief summary of the problem. A copy of your original sales receipt must be included for warranty consideration. Be sure your name, address, and RMA number are clearly written on the outside of the shipping carton.

NOTICE: Do not ship LiPo batteries to Horizon. If you have any issue with a LiPo battery, please contact the appropriate Horizon Product Support office.

Warranty Requirements

For Warranty consideration, you must include your original sales receipt verifying the proof-of-purchase date. Provided warranty conditions have been met, your Product will be serviced or replaced free of charge. Service or replacement decisions are at the sole discretion of Horizon.

Non-Warranty Service

Should your service not be covered by warranty, service will be completed and payment will be required without notification or estimate of the expense unless the expense exceeds 50% of the retail purchase cost. By submitting the item for service you are agreeing to payment of the service without notification. Service estimates are available upon request. You must include this request with your item submitted for service. Non-warranty service estimates will be billed a minimum of ½ hour of labor. In addition you will be billed for return freight. Horizon accepts money orders and cashier's checks, as well as Visa, MasterCard, American Express, and Discover cards. By submitting any item to Horizon for service, you are agreeing to Horizon's Terms and Conditions found on our website http://www.horizonhobby.com/content/service-center_render-service-center.

ATTENTION: Horizon service is limited to Product compliant in the country of use and ownership. If received, a non-compliant Product will not be serviced. Further, the sender will be responsible for arranging return shipment of the un-serviced Product, through a carrier of the sender's choice and at the sender's expense. Horizon will hold non-compliant Product for a period of 60 days from notification, after which it will be discarded.

10/15

WARRANTY AND SERVICE CONTACT INFORMATION







Country of Purchase	Horizon Hobby	Contact Information	Address
United States of America	Horizon Service Center (Repairs and Repair Requests)	servicecenter.horizonhobby.com/RequestForm/	2904 Research Road Champaign, IL 61822
	Horizon Product Support (Product Technical Assistance)	productsupport@horizonhobby.com 877-504-0233	
	Sales	websales@horizonhobby.com 800-338-4639	
European Union	Horizon Technischer Service	service@horizonhobby.eu	Hanskampring 9 D 22885 Barsbüttel, Germany
	Sales: Horizon Hobby GmbH	+49 (0) 4121 2655 100	

WEEE NOTICE



This appliance is labeled in accordance with European Directive 2012/19/EU concerning waste of electrical and electronic equipment (WEEE). This label indicates that this product should not be disposed of with household waste. It should be deposited at an appropriate facility to enable recovery and recycling.

SPECIFICATIONS • SPEZIFIKATIONEN • SPÉCIFICATIONS • SPECIFICHE

	86.46 in (2196 mm)
	62.32 in (1583 mm)
	10.75 –11.5 lbs (4.95–5.20 kg)
	<ul style="list-style-type: none"> • 4-Stroke glow: 1.25 cu. in. (20.52 cc) • 4-Stroke gas: 1.25 cu. in. (20.52 cc) • 4-Takt Verbrenner: 1.25 cu. in. (20.52 cc) • 4-Takt Benzin: 1.25 cu. in. (20.52 cc) • Méthanol à quatre temps : 1.25 cu. in. (20.52 cc) • Essence à quatre temps : 1.25 cu. in. (20.52 cc) • 4 tempi a candele: 1.25 cu. in. (20.52 cc) • 4 tempi a gas: 1.25 cu. in. (20.52 cc)
	<ul style="list-style-type: none"> • 5065-450Kv Brushless Outrunner • 5065-450Kv bürstenloser Außenläufer • Cage tournante sans balais 5065-450Kv • 5065-450Kv Brushless Outrunner
	<ul style="list-style-type: none"> • 6+ channel with 6-7 servos • 6+ Kanäle mit 6-7 Servos • 6+ canaux avec 6 à 7 servos • 6+ canali con 6-7 servo
	5 ⁵ / ₃₂ inches (139mm) ±1/16 inch (1.5mm)

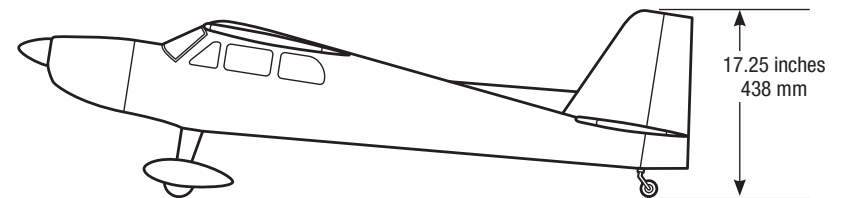
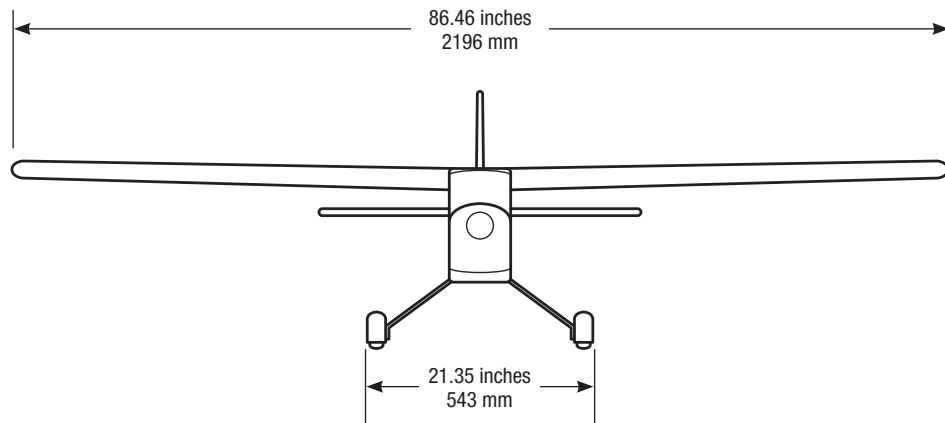
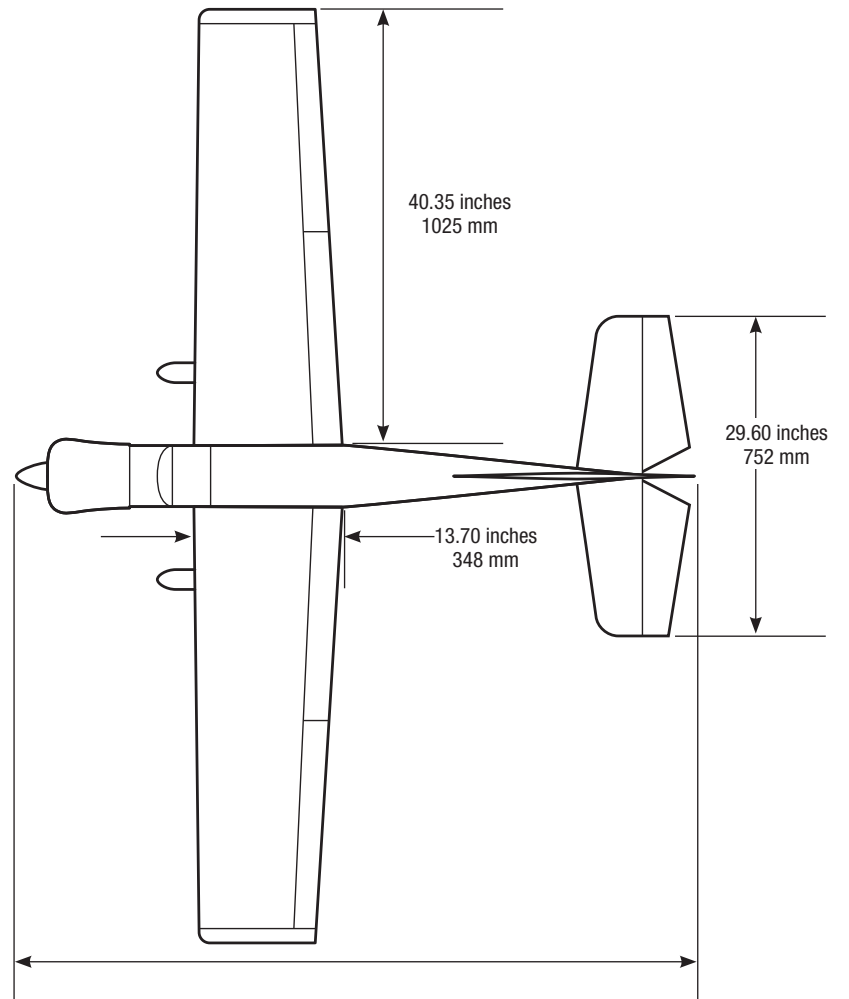

HANGAR 9[®]

© 2026 Horizon Hobby, LLC.

Hangar 9, Sky, AS3X, Avian, IC5, and the Horizon Hobby logo are trademarks or registered trademarks of Horizon Hobby, LLC.

The Spektrum trademark is used with permission of Bachmann Industries, Inc.

All other trademarks, service marks and logos are the property of their respective owners.

Updated 05/2026

756982.1 HAN15040/HAN15075